



# VELOCITY18R Plus

Versatile Centrifuge



Instruction manual

Model VELOCITY18R Plus Versatile Centrifuge

**Dynamica Scientific Ltd**

V1.0

Issue Date: Nov 2023 Ver : V1.0

## MODEL VELOCITY18R Plus VERSATILE CENTRIFUGE





Thank you very much for purchasing Dynamica Velocity18R Plus Centrifuge. For efficient and safety operation, please carefully read this instruction manual before using Velocity18R Plus. Please keep all the manuals of this instrument carefully.

The appearance and performance specifications of the Velocity18R Plus centrifuge are subject to change without prior notice. Please contact Dynamica Scientific or its distributors.

# **Dynamica**

## Safety Reminder

Symbol  is the general international safety sign, please read carefully and fully understand the following safety precautions.

- Comply with the operating requirements of the instruction manual to ensure correct and safe use of the centrifuge.
- Carefully read all safety messages in this manual and the safety instructions on the equipment.
- Safety messages are labeled as follows. The safety symbol  is in combination with words of “WARNING” and “CAUTION” to notify users the potential danger. The definitions of the two combinations are as follows:

### **WARNING: Personal danger**

Warning indicates any condition or practice, on or practice, which if not strictly observed, could result in personal injury or possible death.

### **CAUTION: Possible damage to equipment**

Caution indicates any condition or practice, which if not strictly observed or remedied, could result in damage or destruction of the equipment.

**NOTE:** indicates an area or subject of special merit, emphasizing either the product's capability or common errors in operation or maintenance.

- Do not use the centrifuge in any way which is not mentioned in this manual. Please contact Dynamica technician if you have any questions.
- This manual has given a relatively complete reminder of potential hazards. However, users still need to be alert to unpredictable events and use the centrifuge with caution.



## **WARNING:**

- This centrifuge is not explosion proof. It is prohibited to separate sample materials that are flammable, explosive, or have chemical reactions that cause large amounts of dangerous gases.
- This centrifuge is not used to separate hazardous substances such as toxic, radioactive materials or materials containing harmful microbial contamination.
- The sealing ring and its related parts only form part of the enclosure protection system and cannot be relied upon as the only way to protect workers and the environment when handling hazardous substances.
- If harmful or hazardous substances spill or enter the centrifuge, the user must clean and disinfect according to the decontamination procedures in this manual. Before using cleaning and disinfection methods not recommended in this manual, the user should consult Dynamica or its authorized agency. To ensure that this method does not damage the centrifuge.
- If on-site assistance from Dynamica or its authorized agency is required, the centrifuge must be disinfected and decontaminated in advance. Make sure to notify the service representatives of the use of such materials.
- Do not install the centrifuge in or near places where inflammable gases are generated or chemicals are stored.
- Do not place dangerous substance within 300mm of the equipment.
- Do not touch the power cord and power switch with wet hands to prevent electric shock.
- For safety reasons, when the centrifuge is running, keep a clearance of 300mm between personnel and the equipment.
- While the rotor is rotating, never override the door lock. If emergency unlocking is required, make sure the rotor has stopped completely before performing emergency unlocking.
- Check the function of the gas spring regularly. If the gas spring is damaged, replace it immediately.
- Except by our service personnel, unauthorized repairs, disassembly, and other services maintenance applied to the centrifuge are strictly prohibited.



 **CAUTION:**

- The centrifuge must be located on a firm and levelled table.
- Make sure the centrifuge is levelled before running it.
- When opening the centrifuge lid, make sure that the angle between the lid and the body is greater than 70 degrees.
- When closing the centrifuge lid, do not put your hands between the lid and the body.
- Do not move the centrifuge when it is running.
- When there is liquid in the centrifuge chamber, please wipe it with a dry cloth in time to avoid contaminating the sample.
- Before running the centrifuge, make sure that the centrifuge chamber is clean. Remove any foreign objects in the centrifuge chamber, such as centrifuge tube fragments, etc.
- After centrifugation, you need to open the centrifuge lid to evaporate the water vapor and keep the centrifuge chamber dry and tidy.
- **CCAUTION to rotors:**
  - Before using the rotor, check whether there is corrosion or damage on the surface of the rotor. If there are such problems, stop using it.
  - set speed of the equipment cannot exceed the minimum maximum allowable speed in the rotor assembly (rotor, bucket or other adapter).
  - Do not exceed the allowed imbalance tolerance.
  - The centrifuge tubes and bottles used should be within their allowable capacity.
  - Make sure to use the same type of bucket.
  - If the rotor has a cover, make sure the cover is tightened before operation.
  - When using a rotor with a wind shield, make sure to cover the wind shield every time you run it. If there is liquid splashed in the wind shield, please wipe it off in time. Make sure there is no liquid in the wind shield before each operation.
- If an abnormality occurs during operation, please stop the centrifuge immediately. Contact the Dynamica service representative and inform the service representative of the error code displayed.
- Earthquakes may cause damage to the centrifuge. If abnormal conditions occur, please contact Dynamica service representatives.
- When using this centrifuge, make sure to operate it according to the instructions in the manual. Failure to operate according to the instructions may cause dangerous accidents, and illegal operation will also cause the protective measures to fail.

# Table of Contents

 SAFETY REMINDER .....	III
<b>1. PERFORMANCE SPECIFICATIONS.....</b>	<b>9</b>
1.1    STRUCTURE .....	9
1.2    PURPOSE .....	9
1.3    SPECIFICATIONS AND PERFORMANCE INDICATORS .....	9
1.4    FIRMWARE VERSION .....	10
<b>2. ENVIRONMENTAL CONDITIONS.....</b>	<b>11</b>
2.1    BASIC OPERATING CONDITIONS .....	11
2.2    TRANSPORT AND STORAGE CONDITIONS .....	11
<b>3. INSTALLATION .....</b>	<b>12</b>
3.1    OPEN THE PACKAGING BOX .....	12
3.2    INSTALLATION.....	12
3.3    CONNECTION OF POWER CORD AND GROUND WIRE .....	13
3.4    LEVELING .....	13
<b>4. SCREEN OPERATION AND INSTRUCTIONS.....</b>	<b>15</b>
4.1    PARAMETER SETTINGS.....	17
4.1.1    Set the speed.....	17
4.1.2    Set temperature .....	17
4.1.3    Set time .....	18
4.1.4    Set Acceleration / deceleration .....	20
4.2    PROGRAM SETTINGS .....	21
4.3    ECO SETTINGS.....	24
4.4    PRE - COOLING SETTINGS .....	25
4.4.1    Normal pre-cooling .....	25
4.4.2    Schedule pre-cooling.....	27
4.5    FAST-SPIN CENTRIFUGATION .....	29
4.6    OPEN THE DOOR LID .....	29
4.7    START AND RUN.....	30
4.7.1    Acceleration process .....	30

4.7.2	Stable operation .....	31
4.8	MENU .....	32
4.8.1	Setting .....	33
4.8.2	User lock .....	39
4.8.3	Contact & support .....	40
4.8.4	Alert .....	41
4.8.5	Run history .....	42
4.8.6	Export .....	43
4.8.7	Rotor catalog .....	44
4.8.8	Other .....	45
4.9	USER LOGIN .....	46
4.10	USER SWITCHING .....	48
<b>5.</b>	<b>STRUCTURE .....</b>	<b>49</b>
<b>6.</b>	<b>ROTOR AND CENTRIFUGE TUBES .....</b>	<b>51</b>
6.1	ROTORS .....	51
6.2	CLEANING AND STERILIZING TUBES AND BOTTLES .....	53
6.3	NOISE OF ROTOR OPERATING AT FULL LOAD .....	55
<b>7.</b>	<b>CENTRIFUGE OPERATION .....</b>	<b>56</b>
7.1	NORMAL OPERATION .....	56
7.2	RELATIVE CENTRIFUGAL FORCE (RCF) OPERATION .....	57
7.3	PROGRAM OPERATION .....	58
7.4	PRE-COOLING OPERATION .....	58
7.5	FAST-SPIN OPERATION .....	58
7.6	OPERATION RECORDS .....	58
7.7	DATA EXPORT .....	59
7.8	USER MANAGEMENT .....	59
<b>8.</b>	<b>ACCELERATION AND DECELERATION RATES .....</b>	<b>60</b>
<b>9.</b>	<b>TEMPERATURE CONTROL .....</b>	<b>61</b>
9.1	SAMPLE TEMPERATURE DURING CENTRIFUGATION .....	61
9.2	HIGH TEMPERATURE CENTRIFUGATION .....	62
<b>10.</b>	<b>MAINTENANCE .....</b>	<b>63</b>

10.1	DAILY MAINTENANCE.....	63
10.2	CLEANING AND DISINFECTION .....	64
10.3	ROUTINE INSPECTION AND REPLACEMENT OF CONSUMABLES PARTS.....	65
<b>11.</b>	<b>TROUBLESHOOTING.....</b>	<b>66</b>
11.1	COMMON MALFUNCTION LIST .....	66
<b>12.</b>	<b>FREQUENT PROBLEMS AND SOLUTION .....</b>	<b>68</b>
12.1	HOW TO OPEN THE DOOR LID .....	68
12.2	HOW TO REMOVE THE ROTOR STUCK TO THE SHAFT .....	69
12.3	DOOR LOCK CANNOT BE LOCKED .....	69
<b>13.</b>	<b>ROTATING RADIUS OF APPLICABLE ROTORS .....</b>	<b>70</b>
<b>14.</b>	<b>CALCULATION OF RELATIVE CENTRIFUGAL FORCE (RCF) .....</b>	<b>71</b>
<b>15.</b>	<b>REPLACEMENT OF FUSE .....</b>	<b>72</b>
<b>16.</b>	<b>GUARANTEE .....</b>	<b>73</b>
<b>17.</b>	<b>AFTER-SALES SERVICE .....</b>	<b>74</b>

# 1. Performance Specifications

## 1.1 Structure

This centrifuge product consists of a control system, centrifugal chamber, drive system, rotor, refrigeration system and safety protection device.

## 1.2 Purpose

This centrifuge is mainly used in chemistry laboratories and laboratories to separate suspension by sedimentation.

Only trained personnel are allowed to operate this centrifuge and its accessories.

Before use, please read the operating instructions and usage instructions of the accessories carefully and become familiar with the operation procedure of the centrifuge.

## 1.3 Specifications and performance indicators

Maximum speed	18000rpm
Maximum relative centrifugal force	30318×g
Maximum capacity	4×300ml
Time	1 second ~ 99 hours 59 minutes 59 seconds ~ HOLD (continuous operation)
Temperature setting range	-20°C~40°C
Acceleration/deceleration profile	(1~11)/(0~11) (Profile 11 is the steepest profile)
Motor	AC Inverter Motor
Refrigerant	Environmentally friendly refrigerant R290
Program memory	100
Safety features	Dual-lock door lid, overspeed detection, overtemperature detector, imbalance protection, status diagnosis system
Device classification	Class I
Power supply	220-230VAC, 50 / 60Hz, 1800VA
Dimensions (mm)	670mm × 625mm × 380mm (length × width × height)
Weight	88kg
Other functions	Auto-rotor recognition, RPM/RCF conversion, Pre-cooling mode, FAST-SPIN function, process display, user rights management, history record, data export, timing mode optional, scheduled pre-cooling, ECO energy saving, etc.

## 1.4 Firmware version

Firmware release version: V1

## 2. Environmental conditions

### 2.1 Basic operating conditions

- 1) The altitude does not exceed 2000 meters,
- 2) Power supply : 220-230VAC, 50/60Hz, 10A,

It is recommended to install an emergency switch to ensure that the power is cut off in case of failure. The emergency switch is best installed outside the room or near the exit.

- 3) Ambient temperature: 5°C ~ 40°C,
- 4) Relative humidity: ≤80%,
- 5) There is no surrounding vibration or airflow that affects performance.
- 6) There is no conductive dust, explosive gas or corrosive gas in the surrounding air.

### 2.2 Transport and storage conditions

- 1) Ambient temperature range: -40°C ~ +55°C.
- 2) Relative humidity range: ≤80%.



## 3. Installation

This section describes the installation of the centrifuge. The user must follow the instructions in this chapter; remember that the rotor must be removed before moving the centrifuge.

### **⚠ WARNING:**

- **Improper power connection can damage the equipment.**
- **Please check whether the power supply meets the requirements before connecting the power supply.**

### 3.1 Open the packaging box

Untie the packaging tape, remove the top cover of the packaging box, and verify the centrifuge accessories, instruction manual and packing list. Then lift the centrifuge upwards and place it gently on the designated workbench.

(Note that when lifting the centrifuge, several people need to lift the four corners on each side at the same time, and then put it down gently)

### 3.2 Installation

- 1) The centrifuge must be installed on a solid, flat and levelled table. Ensure that the four feet of the equipment are in contact with the table. Do not install the equipment on a sliding table or otherwise it will easily cause greater vibration.
- 2) The ideal ambient temperature is  $20^{\circ}\text{C} \pm 5^{\circ}\text{C}$ . Avoid exposing to direct sunlight.
- 3) Allow 300mm clearance on both sides, front and rear of the equipment, which is the safe distance of the centrifuge. After the installation position is fixed, this range should be marked around the centrifuge, which can also ensure the cooling effect of the equipment.
- 4) There should be no heat source or water leakage near the equipment or otherwise, it may easily lead to an increase in sample temperature or cause equipment failure.

**⚠ WARNING: Do not put any hazardous substance within 30cm nearby the centrifuge to avoid the leakage of hazardous substance due to the large vibration of the centrifuge in extreme circumstances.**

### 3.3 Connection of power cord and ground wire

- 1) The centrifuge uses a three-core power cord, and the plug is a Type E plug with 2 round round-pin AC power plug, which can be directly connected to the main power socket.  
(**NOTE:** The plug should be unplugged every day off or if it is not used for a long time.)
- 2) The laboratory power supply must meet the laboratory electrical safety requirements, and a dedicated line must be provided to provide independent power supply to the centrifuge. This dedicated line is equipped with a circuit breaker. The power requirement is 220VAC, 10A with a good grounding terminal.
- 3) The emergency switch can be connected in series to the front end of the centrifuge power cord and installed outside the room or near the exit to ensure that the power supply can be cut off in time in the event of a failure.
- 4 ) When using other power cord accessories, you must use a power cord with the same specifications and parameters as specified here. The total length of the power cord must not exceed 3 meters.

 **WARNING:**

- **Do not touch the power cord with wet hands to prevent electric shock.**
- **The centrifuge must be well grounded.**

### 3.4 Leveling

- 1) Turn on the power switch. After the equipment self-tests, open the door lid, and then turn off the power switch. If the equipment is not connected to the power supply, you can refer to Section 11.1 to open the door lid.
- 2) Place a level on the top the shaft (see the picture below). Rotate the shaft for more than one turn. Check and confirm whether the bubble is always in the center of the mark line inside the vial of the level. Then the centrifuge is leveled.

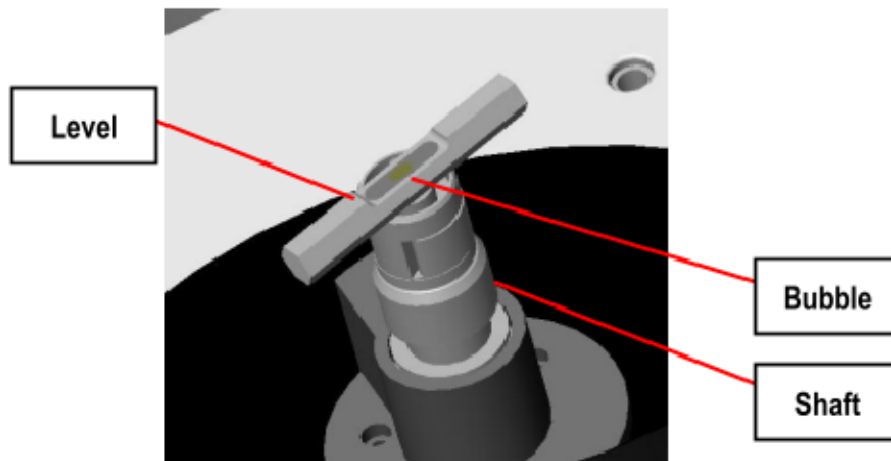

- 3) If the centrifuge is not leveled, adjust the four feet under the chassis of the equipment (see the picture below) until it is levelled (the bubble is in the center of the level). During the adjustment process, keep rotating the drive shaft and observe the position of the bubble. Adjustment method: View from below of the centrifuge and then loosen the locking nut first. Then loosen it counterclockwise, then lock it. Rotate the legs clockwise to lower the equipment, and vice versa to raise it.
- 4) After the centrifuge is leveled, make sure that all four legs are standing stably on the table and prohibit individual legs from floating. You can push the equipment gently with your hands to see if it shakes.
- 5) Once the centrifuge is leveled, tighten the locking nuts on each foot.

⚠ **Warning: The centrifuge must be leveled before operation, otherwise it may easily cause excessive vibration and even damage the equipment.**

## 4. Screen operation and instructions



### Status Bar :

- Product model: Velocity18R Plus
- Rotor model (automatic recognition): FA15G
- Date and time: 2023-10-12 13:48:08
- Door lock status icon (blue when open, disappears when closed)
- USB status icon (blue when connected, white when not connected)
- WiFi status icon (blue when on, white when off)
- User lock status icon (blue when on, white when off)

### Parameter settings:

- Speed setting
- Temperature setting
- Time settings: hours, minutes, seconds
- Program selection
- Acceleration / Deceleration profile selection

**Task bar:**

- Home: Home screen
- Precooling: Precooling screen
- Fast-spin: Fast-spin centrifugation
- Start /Stop: Start/Stop centrifugation
- Open: Door opening button
- ECO: Energy saving selection screen
- Menu: Menu setting screen

**Note:** The display screen has an energy-saving function. If the screen is not operated for a long time, the brightness of the screen will decrease. When operating again, you need to click any position on the screen to restore the brightness before proceeding with the next operation.

## 4.1 Parameter settings

### 4.1.1 Set the speed



1. Press the Speed unit field to select rotation speed (rpm) or relative centrifugal force (g) mode.

- rpm: set the rotation speed
- g: set relative centrifugal force

2. Press on the Speed field and the speed input window opens.

3. Set the speed by typing the speed in the number pad

4. Press Enter, the entered rotation speed or relative centrifugal force is

saved, and the input window is closed.

**NOTE:** When there is no speed input window, press the unit field of Speed to achieve real-time switching of rotation speed and relative centrifugal force (based on the currently displayed rotor).

### 4.1.2 Set temperature



1. Press the Temp field and the temperature input window will open.

2. Set the temperature.  
Value range: - 20°C -40°C

3. Press Enter.

The entered temperature is saved and the input window is closed.

### 4.1.3 Set time



1. Press the hour field of Time, and the time input window will open.
2. Set the hour.  
Value range: 0-99
3. Press Enter.  
The entered hours are saved and the entry window is closed.



1. Press the minute field of Time to open the time input window.
2. Set the minutes.  
Value range: 0-59
3. Press Enter.  
The entered minutes are saved and the entry window is closed.



1. Press the seconds field of Time to open the time input window.
2. Set seconds.  
Value range: 0-59
3. Press Enter.  
The entered seconds are saved and the input window is closed.

**NOTE:** There is no need to set the minutes and seconds in sequence. Just set them according to the parameters that need to be set.



When there is no time input window, press Time to quickly switch between Timed mode and Continuous mode.



- Timed mode: specific centrifugation time can be set.
- Continuous mode: The time is displayed as HOLD to achieve continuous centrifugation.

#### 4.1.4 Set Acceleration / deceleration



1. Press the Accel/Decel Profile field, and the Accel/Decel Profile selection window will open.
  2. Select the Accel/Decel Profile  
Accel Profile range: 1-11  
Decel Profile range: 0-11
  3. Press Confirm
- The selected profile is saved and the Accel/Decel Profile window is closed.

## 4.2 Program settings



Press on the Prog field and the program list window opens.

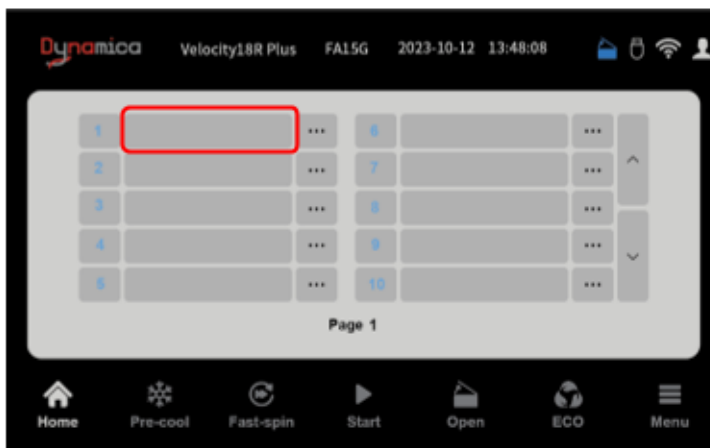

Press the program name to pop up the program name naming window to change the program name or add a new program name.

**NOTE:** A blank program can also be pressed to name the program.

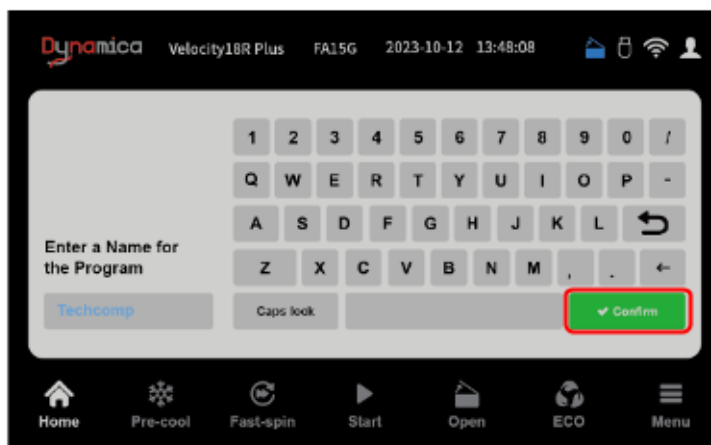

1. Enter the program name according to your requirements

The program name is limited to 10 characters.

2. Press Confirm to confirm



Press the details field and the program editing window opens.

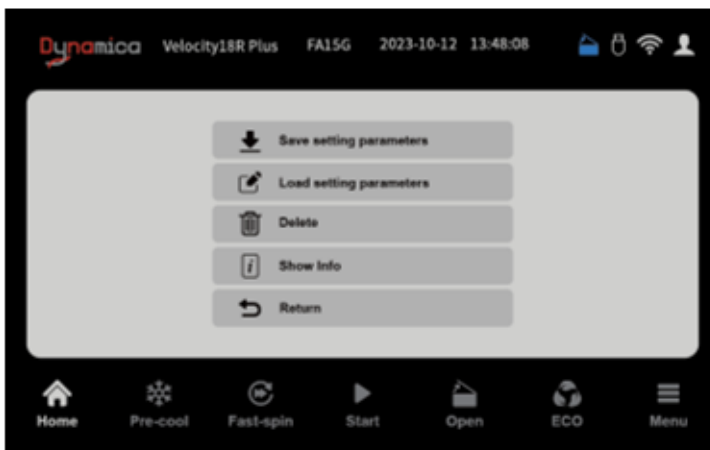

**Save setting parameters:** Save the setting parameters to the program. Press to pop up a window prompting that the program editing window will be restored after successful saving.

**Loading setting parameters:** Use the program parameters to run. Press to return to the Home screen and assign the program parameters to the setting parameters.

**Delete:** Delete the program parameters.

**Show Info:** Display detailed parameter information of the program

**Return:** Return to the program list

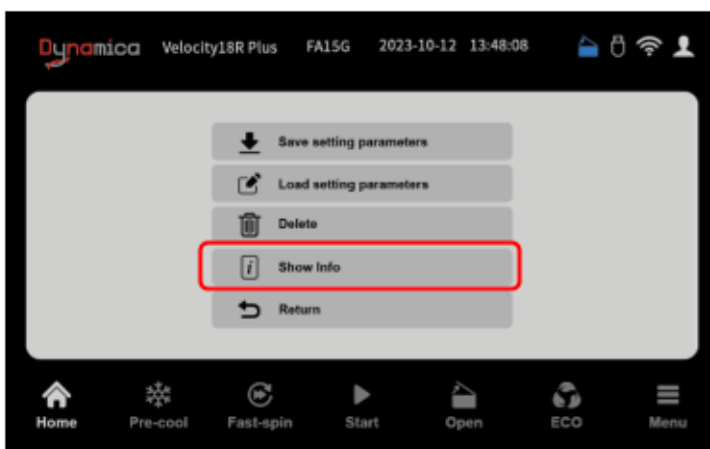

Press Show Info opens the program detailed information display window.



Press Back to return to the program editing screen



Press the number field next to Prog to pop up the program number input window.



After entering the program number, you can enter directly to the program editing window. In this way, you can save the program, use the program, and check the program according to the introduction of the program editing window.

### 4.3 ECO settings

ECO is defined as an energy-saving mode. If ECO mode is not turned on, the centrifuge always maintains the set temperature when the centrifuge is powered on and the door lid is closed, that is, the compressor is always working. When ECO mode is turned on, user can select the ECO mode duration, that is, the length of time the centrifuge can maintain the set temperature when the centrifuge is powered on and the door lid is closed. After this duration, the centrifuge will enter the energy-saving mode, that is, the compressor will stop working.

**NOTE:** When users need to maintain the set temperature of the centrifuge in standby mode, they must promptly confirm the ECO mode status of the centrifuge, that is, enter the ECO mode screen to check the ECO mode settings.



Press the ECO button on the Home screen to pop up the ECO mode setting window.

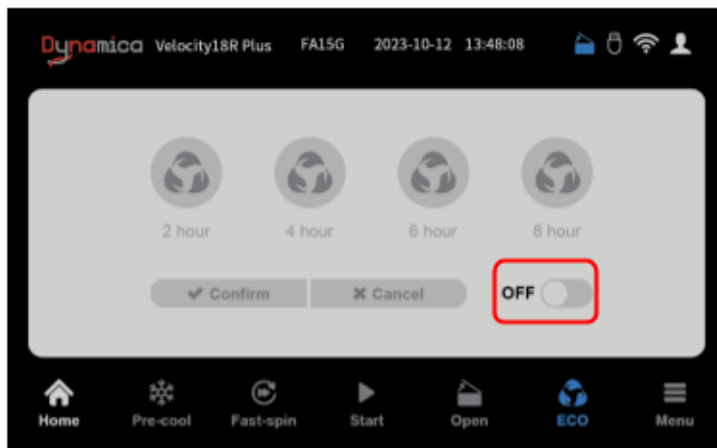

Press the ECO switch to turn on ECO mode.

**NOTE:** Press the ECO switch again to turn off ECO mode.

Select duration (four duration options);

Press Confirm to return to the Home screen.

**NOTE:** Pressing Cancel will not save the ECO mode settings.

## 4.4 Pre - cooling settings

### 4.4.1 Normal pre-cooling

After placing the rotor in the equipment and closing the door cover, enter the pre-cooling screen and set the relevant parameters to achieve equipment pre-cooling. Pre-cooling is performed at the rotor speed of 1,600 rpm by default. The pre-cooling temperature can be set as needed.



**NOTE:** Pre-cooling generally refers to the chamber temperature. Rotor and sample usually pre-cooled in a refrigerator. Longer time is required if pre-cooling the rotor and sample by the pre-cooled function of the centrifuge.

Press Pre-cool button on the Home screen to pop up the pre-cooling setting screen.



Pre-cooling setting screen

Press the temperature area to pop up the temperature input window.



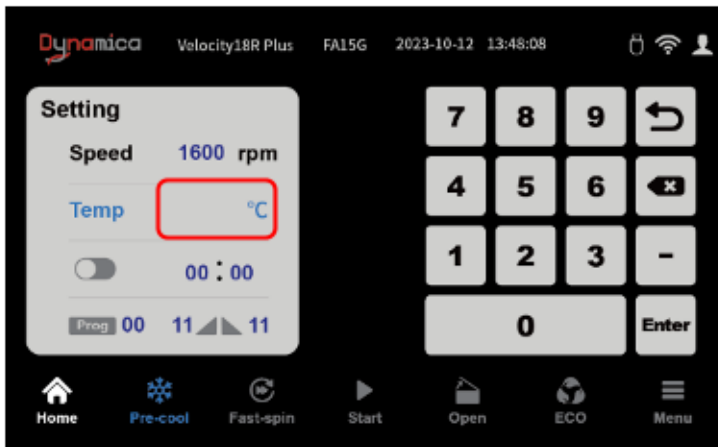

Enter the desired pre-cooling temperature in the temperature input window.

The generally recommended setting temperature range is -20-20 °C

Press Enter to return.



Press StartNow to perform pre-cooling and enter the real-time pre-cooling screen.



Press Stop on the real-time pre-cooling screen to stop pre-cooling.

**NOTE:** The value in the small circle in the lower right corner (25°C) represents the actual temperature of the centrifuge chamber.

The time in the middle is the accumulated running time of the current pre-cooling.

## 4.4.2 Schedule pre-cooling

Scheduled pre-cooling is defined as to perform the pre-cooling the centrifuge at a specific time in the coming future. The temperature and specific time need to be set. The temperature setting is the same as in the pre-cooling setting. If the centrifuge is running at the same time as scheduled pre-cooling, the centrifuge will not perform the scheduled pre-cooling.



Press the scheduled pre-cooling switch in the pre-cooling setting screen to turn on the scheduled pre-cooling function.



Press the hour field and the input window will pop up.

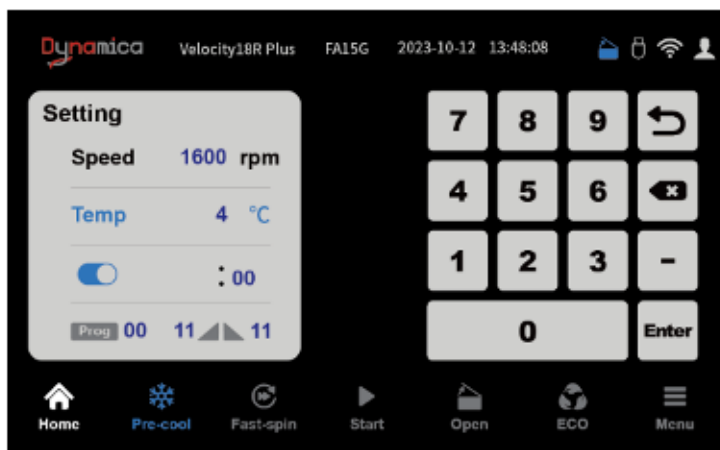

Enter the hour to be scheduled.  
Input range 0 -23

**NOTE:** The setting of minutes is the same as that of hours. The input range of minutes is 0-59 .

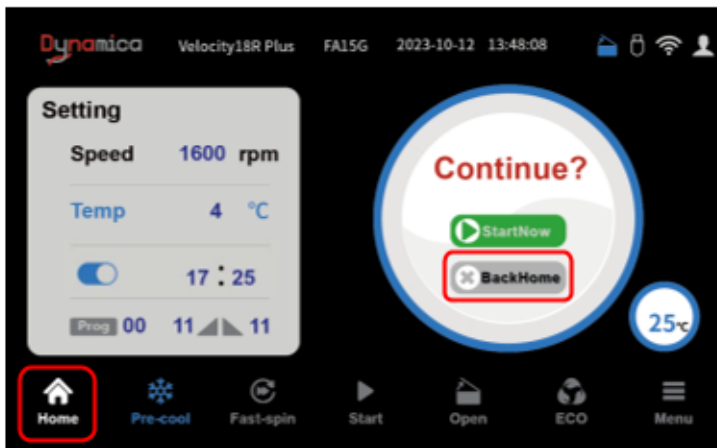

After the time setting is completed, Press BackHome or Home to return to the Home screen to complete the scheduled pre-cooling settings.

**NOTE:** Do not Press StartNow at this moment if you want to schedule the pre-cooling. Pressing StartNow the centrifuge will run the pre-cooling immediately according to the set temperature.

In this setting, the centrifuge remains powered on and will be pre-cooled at 17:25. The precooling setting temperature is 4 degrees Celsius.

## 4.5 Fast-spin centrifugation



Press and hold the Fast - spin button and the centrifuge will run at the setting speed and temperature until the button is released. The spin will stop once the Fast-spin button is released.

## 4.6 Open the door lid



In the Home screen, Press Open button to open the door lid and a blue door lock icon will appear in the Status bar. A “click” sound indicates the door lock is released and unlocked. You can now lift the door lid by pushing it up. The door lid will automatically lock if the door lid is not lifted after 3 seconds and you will hear another “click” sound.

**NOTE:** Closing the door lock requires resetting the microswitch motor in the door lock.

## 4.7 Start and run



Once the parameters are set, close the door lid and Press Start button to perform centrifugation. Press Start button on the Home screen to enter the running screen.

### 4.7.1 Acceleration process

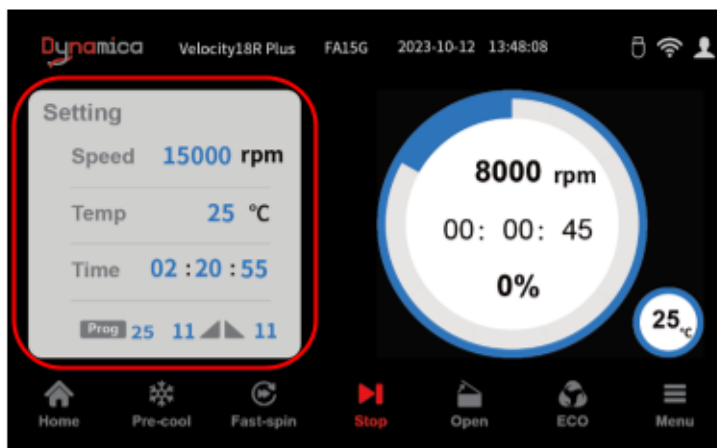

During the acceleration process, the parameter setting window on the left side will be locked and the parameters cannot be changed.

## 4.7.2 Stable operation



- ① — indicates the running time
- ② — 15000 rpm indicates real-time actual speed
- ③ — indicates the running progress
- ④ — indicates the real-time actual temperature of the centrifuge chamber
- ⑤ — During the operation process, the blue annular motion bar will perform circular motion.

As the operation progresses, the white inner circle will be filled with blue gradually until it is full. When the centrifuge is in stable operation, setting parameters can be changed as needed.

During stable operation, press the rpm on the left to set a new parameter to achieve real-time changing of rotation speed and relative centrifugal force.

The centrifuge will stop running after reaching the set time. During this centrifuge process, you can also press the Stop button to stop the centrifugation as needed. Music prompts or voice prompts will be played after the centrifuge stops completely.

## 4.8 Menu



Press the Menu button on the Home screen to pop up the Menu setting window.

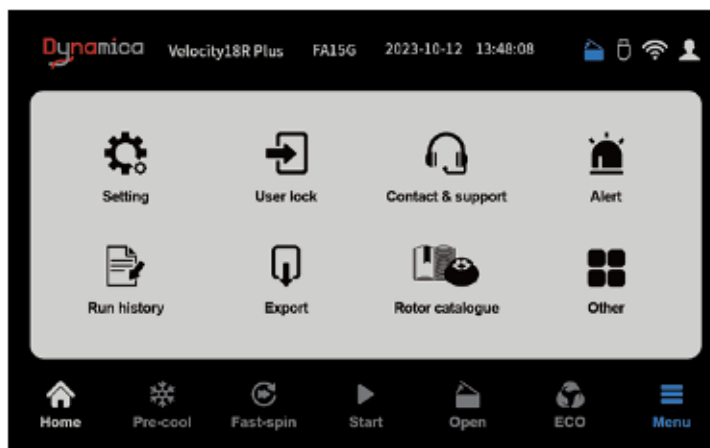

Setting: System settings

User lock: set by the user

Contact & support : After-sales service inquiry

Alert: Alarm code query

Run history: History query

Export: Data export

Rotor catalogue: Rotor information query

Other: Service mode



## 4.8.1 Setting

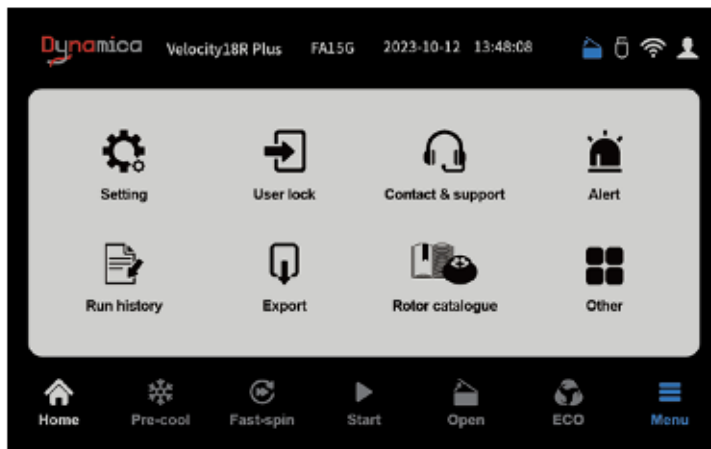

Press Setting in the Home screen will pop up the Setting window.



Date & Time: date and time settings  
Language: Prompt language setting  
User management: User management settings  
**Network: undefined**  
Sound: Prompt voice volume and end centrifugal music selection settings  
Others: other settings  
Press on each button on the right to enter the corresponding setting screen.

### 4.8.1.1 Date&Time

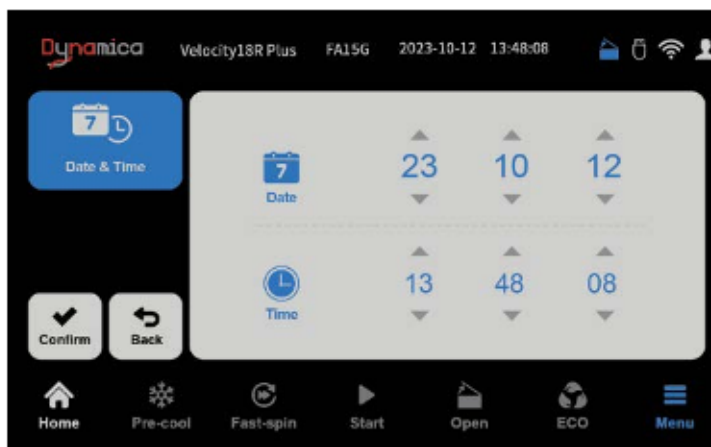

Press the up or down arrow to set the year, month, day, hour, minute, and second.

After setting, press Confirm to return to the previous screen.

### 4.8.1.2 Language



Select the tone language as needed

- Simplified Chinese
- English (UK)

After setting, press Confirm to return to the previous screen.

### 4.8.1.3 User management

- **Create a new user**



If you have the permissions to change (users with unlimited permissions, users with administrator permissions), press on the editing area, and the user editing screen will pop up. You can add users, set passwords, configure permissions and other operations; The selection box on the left display the current user.

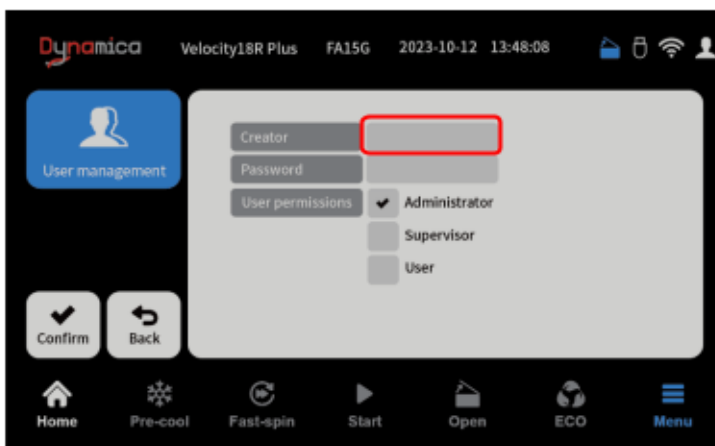

Press the username editing field to pop up the username input window.



Enter the username as needed and press Confirm to return to the user editing screen.

**Please enter 1-10 characters.**



Press the password editing field to pop up the password input window.



Enter the password as needed and press Confirm to return to the user editing screen.

The password length is 1-6 characters. If it exceeds 6 characters, a pop-up window will prompt that the password creation fails.

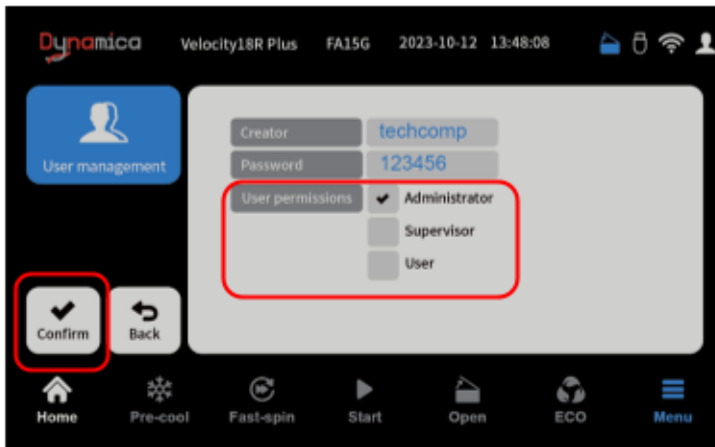

Press the permission selection field to grant the user permissions based on user access level.

Administrator: Administrator rights

Supervisor: Supervisor rights

User: User rights

Press Confirm on the left to return to the user list and create the user successfully.



User: techcomp

User permission: Administrator

Press Delete on the right to delete the current user.

Press the left / right arrow at the bottom page to browse different pages.

Press Back to return to the previous screen.

- Check user/change username/change password/change permissions



Press on the edit icon of an existing user to perform editing operations such as viewing users / changing usernames / changing passwords / changing permissions. For specific operations, please refer to Create a New User.

Press Back to return to the previous screen.

## ● User rights management

user	User lock	Create program	Remove program	Change program name	Create user	delete users	Modify user name	Change user permissions
Administrator	√	√	√	√	√	√	√	√
Supervisor	×	√	√	√	×	×	×	×
User	×	×	×	×	×	×	×	×

**NOTE:** When User Lock function is disabled, the user permission (user01) is set to have all permissions by default. Above table lists the differentiated permissions level of the three types of users. Undifferentiated permissions are not listed in this table.

### 4.8.1.4 Sound

A voice or music will be played as the prompt at the end of centrifugation. You can select music and set the volume level. There are three choices, namely Voice, Music 1 and Music 2. If you select Voice, a voice prompt will be played based on the language set up in the Settings, i.e. Chinese voice prompt will be played if you select the Language to be Chinese and English voice if you select English. If you select Music 1, and music 1 will be played as prompt for end of centrifugation. If you select Music 2, then music 2 will be played.



You can slide to adjust the volume level in the volume adjustment bar.

After selecting and setting, press Back to return to the previous level.

### 4.8.1.5 Others

The default counting of timer function is counting to the set time from zero. The default Time setting mode is Timed. You can change the settings as needed.

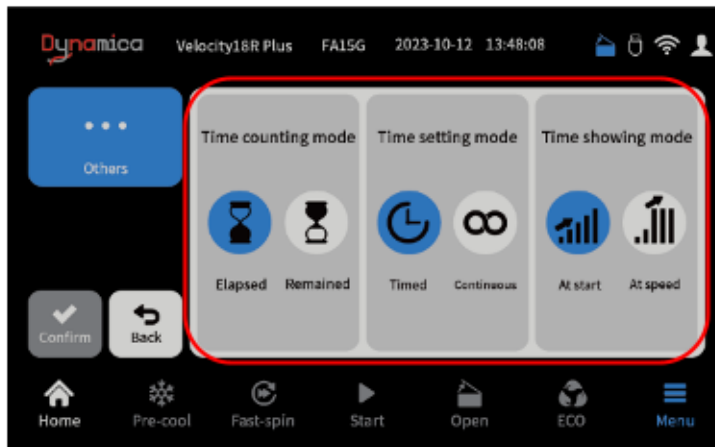

Three modes for timer

- Count-up / Count-down
- Timed / Continuous (associated with pressing Time quick settings in the setting area of the Home screen)
- Timer start at spinning start / Timer start when rotor reach set speed

After selecting settings from the three modes on the right as needed, press

Back to return to the previous screen.

### 4.8.1.6 Return



After completing the settings in the Setting window as needed, press Back to return to the previous screen (Menu window).

## 4.8.2 User lock

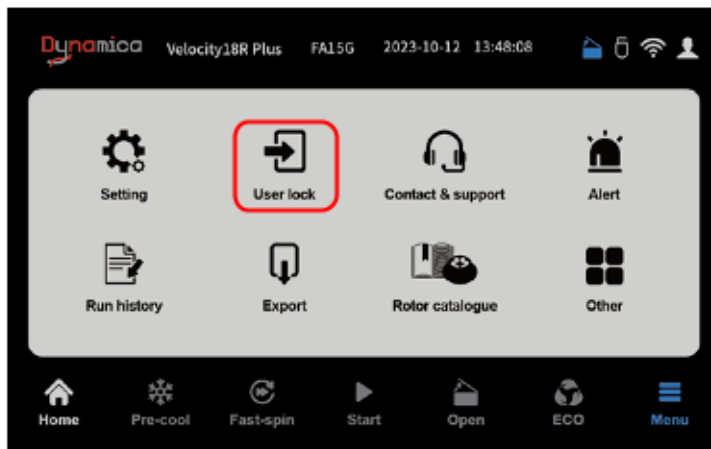

Press User Lock button in the Menu window lock area, pop up User lock setting window.

**NOTE:** Depending on the permissions, some users cannot operate



In the user lock on/off selection button, select to enable or disable the user lock.

After the user lock is turned on, the user icon in the status bar will display in blue. At the same time, the user is set to have all permissions (user 01). After turning on and off the centrifuge, user needs to enter password to log in. Press User icon on Home screen to switch between different users.

### 4.8.3 Contact & support

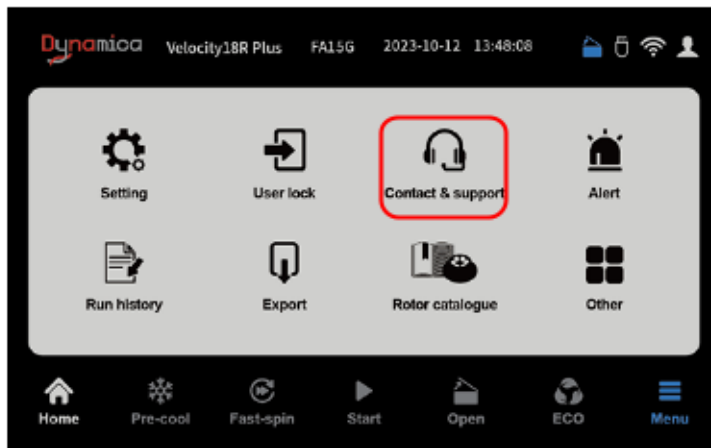

Press the Contact & support button in the Menu window to pop up the after-sales service inquiry window.

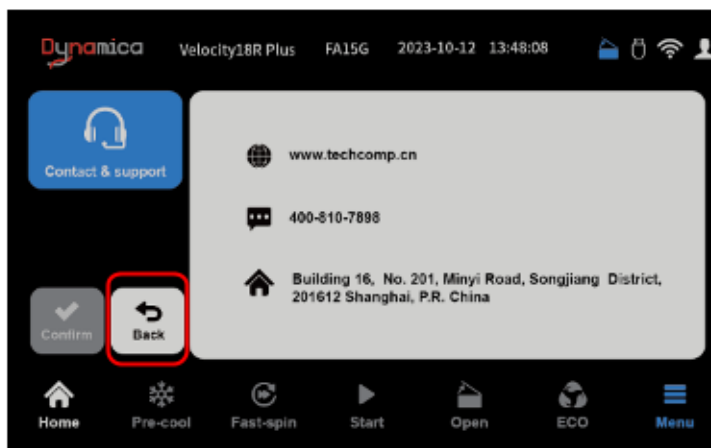

Press Back to return to the previous screen.



## 4.8.4 Alert

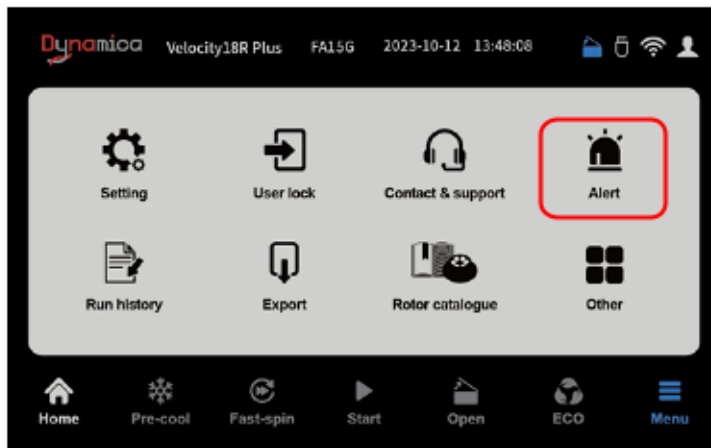

Press the Alarm button in the Menu window to pop up the alarm information query window.

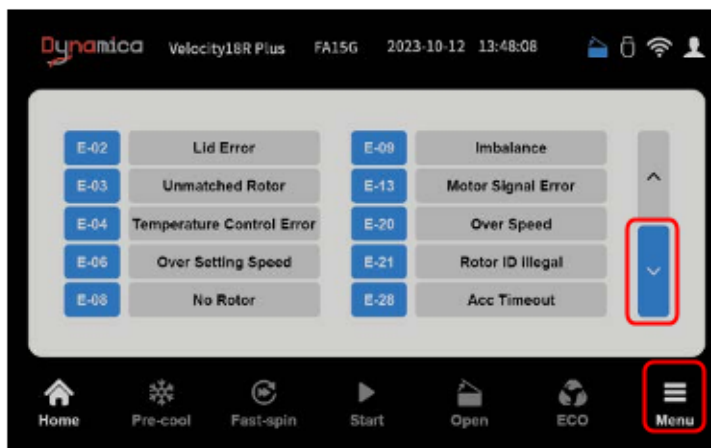

Press Page Down to scroll to next page for query.

Press Menu to return to the Menu window.

## 4.8.5 Run history

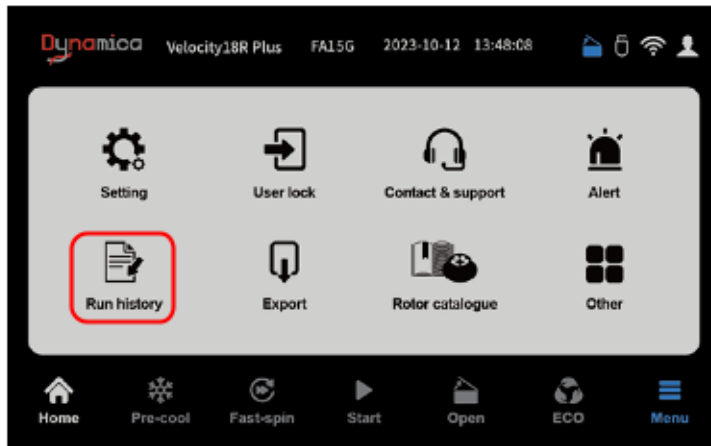

Press the Run history button in the Menu window to pop up the history query window.



Run-OK: Run until the end of the set time

PowerOn : Power on record

Error XX: Failure

Halt : Manual stop during operation

Press Clear History to clear the history.

Please use this with caution.

## 4.8.6 Export

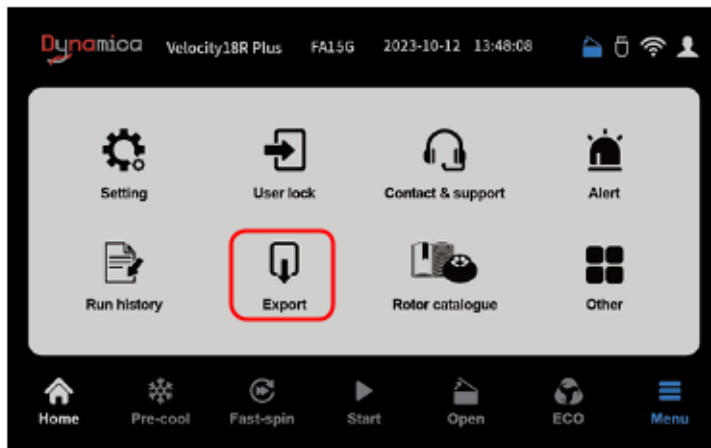

Press the Export button in the Menu window to pop up the data transfer window.

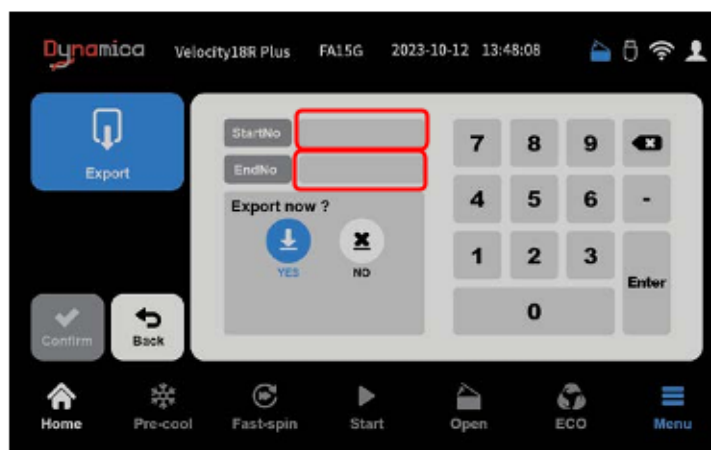

Press the StartNo and EndNo fields respectively to enter the starting sequence number and ending sequence number of the transmitted data;

Press Yes to start data transfer. After the data transfer is completed, it will automatically return to the Menu window.

**NOTE:** Before data transfer, make sure the USB disk is plugged in or otherwise an alert sound will be play and the data transfer will fail.

After data transfer is finished successfully, a LIST.csv file will be generated on the USB disk. The CSV file can be opened and viewed with MICROSOFT EXCEL on any computer. Please copy and backup the successfully transferred files out of the USB disk immediately or otherwise the previously transferred files will be overwritten in the next transfer.

## 4.8.7 Rotor catalog

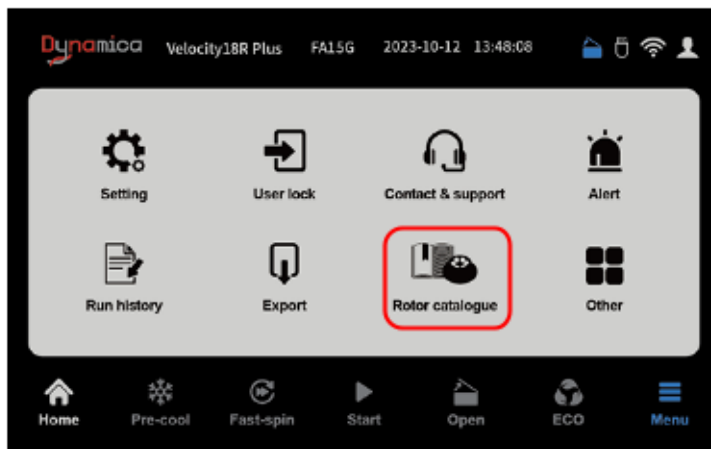

Press the Rotor catalog button in the Menu window to pop up the rotor information query window.



Press the rotor name to pop up the rotor detailed information window;

Press Up or Down arrow to scroll to next page.

Press Menu to return to the Menu window.

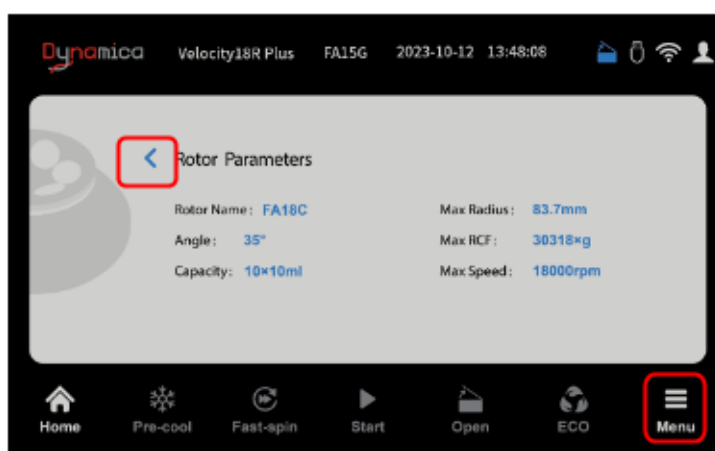

Press the left arrow to return to the previous screen.

Press Menu to return to the Menu window.

## 4.8.8 Other

Other is the service mode window. Users do not have permission to enter and is only open to professional after-sales personnel.

## 4.9 User login

When User lock is turned on, the user is required to log in with a password when power on the centrifuge.



Press the username area to pop up the username input window.

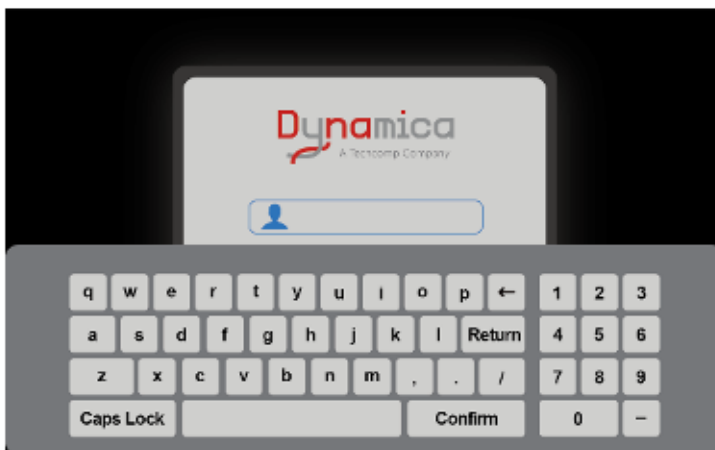

Press on the keyboard to enter your username

Press Confirm to confirm and return

**NOTE:** Press Caps Lock to switch between upper and lower case on the keyboard.



Press the password field to pop up the password input window.

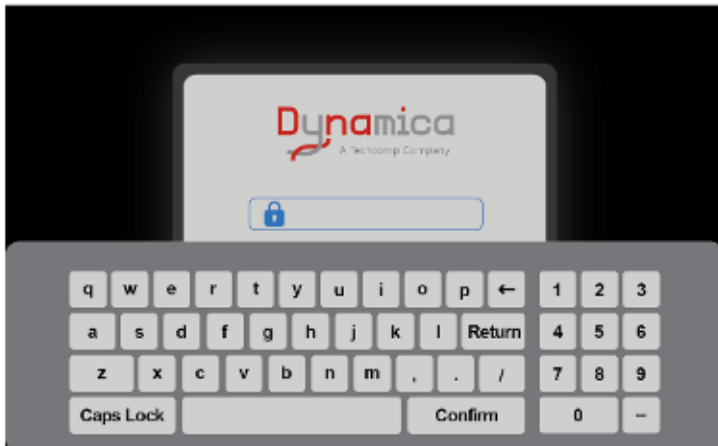

Press on the character on virtual keyboard to enter your password (case sensitive).

Press Confirm to confirm and return.

**NOTE:** Press Caps Lock to switch between upper and lower case on the virtual keyboard.

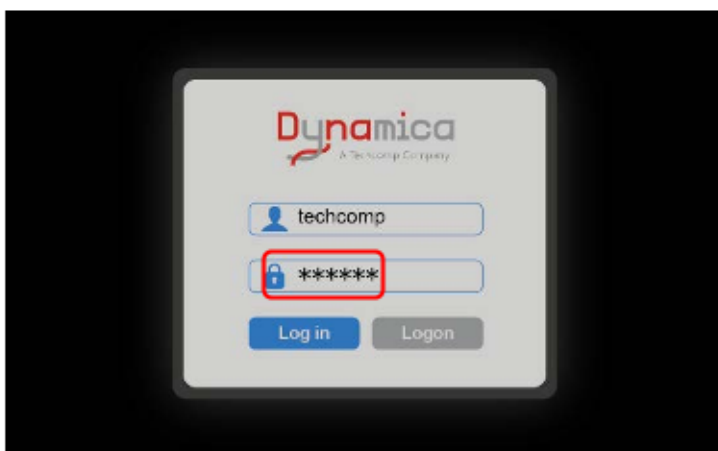

Press Log in to login the centrifuge.

## 4.10 User switching



Press the User icon in the Status bar of the Home screen, and the user login window will pop up. Just follow the user login operation. This shortcut operation can be used to switch to a different user or enable the user lock function.

**NOTE:** When the User lock is on, press the blue User icon to switch users;  
When the user lock is turned off, press the white User icon to turn on the user lock (after successful login)



## 5. Structure

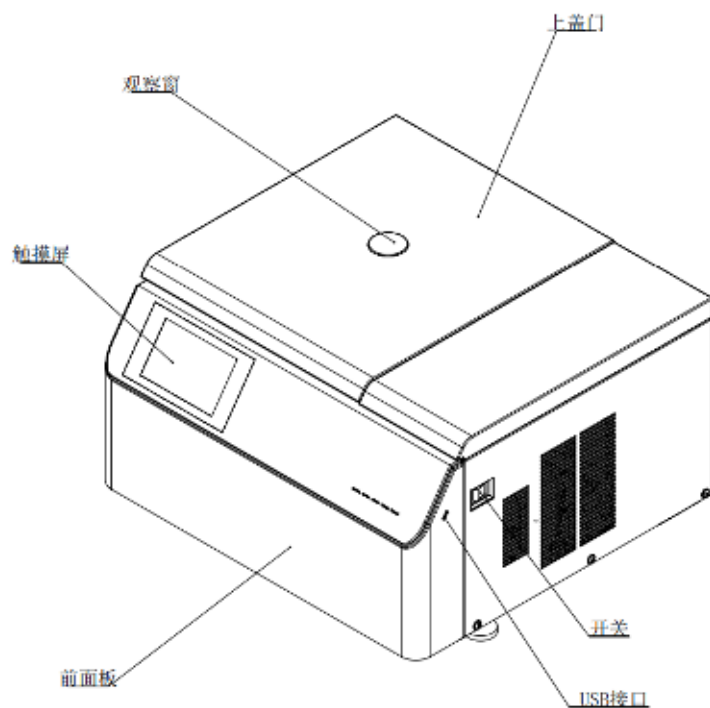

Axonometric drawing

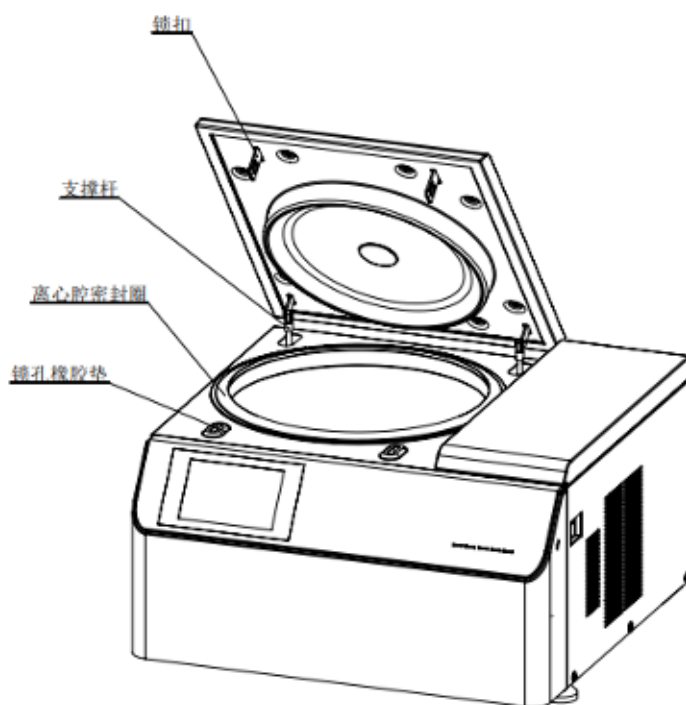

Isometric view of door cover open

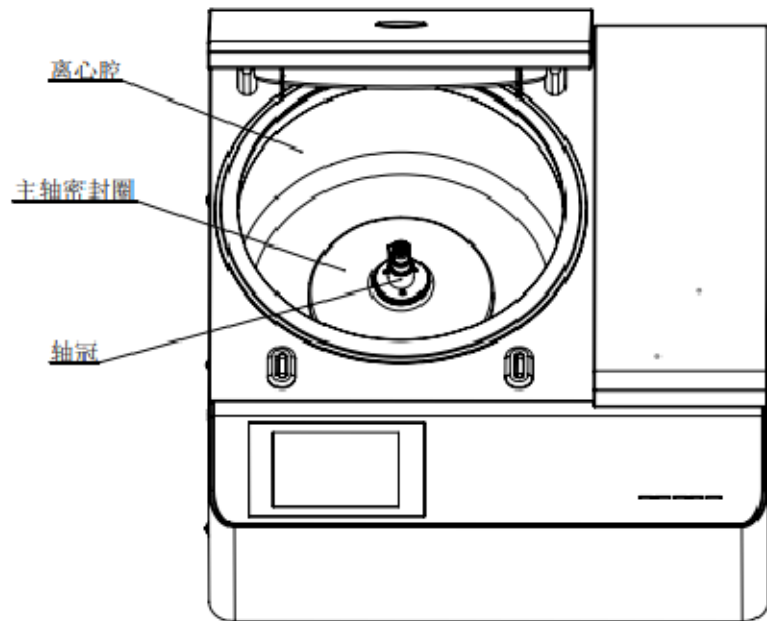

Top view of centrifuge chamber

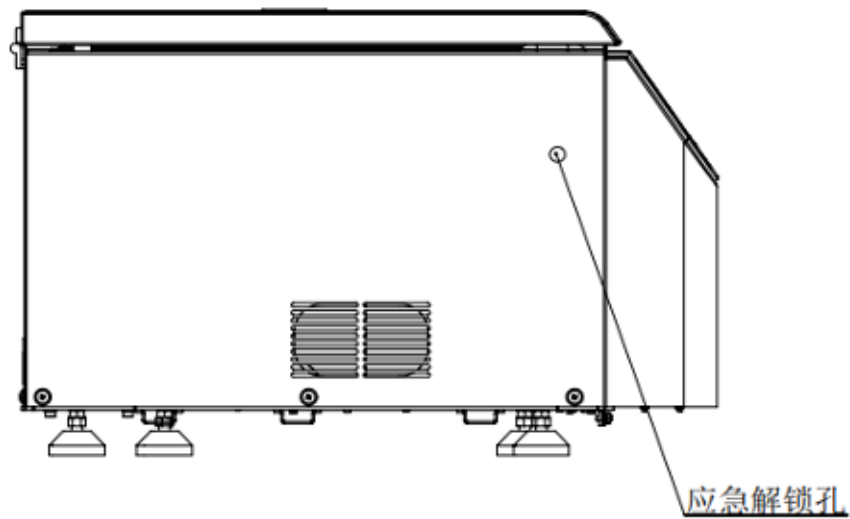

Left view

## 6. Rotor and centrifuge tubes

### **WARNING:**

- **This centrifuge and the rotor are not explosion proof. Never use explosive or flammable samples or have chemical reactions that generate large amounts of dangerous gases.**
- **This centrifuge is not used to separate hazardous substances such as toxic, radioactive materials or materials containing pathogens.**

### 6.1 Rotors

- 1) Prepare the samples to be separated.
  - 2) Put the sample into a centrifuge tube or bottle. Do not exceed the capacity that is specified in the instruction manual.
  - 3) Balance the centrifuge tubes or bottles.
    - See Table 6.1 or the rotor specification for imbalance tolerance of each rotor.
    - Although this centrifuge can accept eye balancing sample, we recommend that the sample are well balanced to prolong its service life.
    - Never intentionally run the centrifuge under unbalanced condition even though the imbalance tolerance is not exceeded.
    - Please load the rotor with the same centrifuge tubes symmetrically. You must use centrifuge tubes of the same type (material, weight, specification).
  - 4) Inspect the rotor
    - Check the rotor and the buckets for corrosion or scratch before use.
    - Check whether the swinging bucket rotor swings smoothly by slightly spinning the rotor manually. Perform periodic maintenance on the rotor.
  - 5) Set balanced tubes or bottles symmetrically on the rotor or rotor rack.
  - 6) Confirm the ID code of the rotor
    - This centrifuge can identify rotors automatically.
    - Each rotor is assigned an ID code. Each rotor is assigned an ID code. After the rotor is identified, the optimum temperature can be automatically obtained. And the function of over speed protection and the speed/RCF display can be realized.
-  **CAUTION:** Sample may leak from the gap between the bottle and its cap if the bottle is fully filled up. Do not add too much sample.

⚠ **CAUTION:** The samples with different composition but same volume have different sedimentation during centrifugation and will cause imbalance. Due to this, the sample with same composition should be placed symmetrically.

⚠ **CAUTION:** If any abnormality such as corrosion or scratches is found, stop using the rotor and contact Dynamica service representative.

⚠ **CAUTION:** Other brands or types of rotors are forbidden on the instrument.

⚠ **CAUTION:** Make sure that the cover is put on the rotor and fixed securely. Otherwise, the rotor or its cover may be dropped off while the instrument is running. That might damage the centrifuge or the rotor.

Table 6.1 Rotor list

No	Rotor	Name	Velocity18R Plus		Centrifuge tube type	Imbalance tolerance
			Maximum speed (rpm)	Maximum RCF (×g)		
1	FA18B	TA18-18-2	18000 rpm	24994 ×g	1.5/2ml	1.5 g/ tube
2	FA18C	TA18-10-10	18000 rpm	30318 ×g	10ml round bottom tube	1.5 g/ tube
3	FA15A	TA15-24-2	15000 rpm	21658 ×g	1.5/2ml	1.5 g/ tube
4	FA15D	TA15-4-100	1 5000 rpm	2 0878 ×g	100ml	3g /tube
5	FA15E	TA15-12-5T	15000 rpm	22639 ×g	5ml conical tube	1g /tube
6	FA15G	TA15-6-50T	15000 rpm	25004 ×g	50ml conical tube	3g /tube
7	FA15H	TA15-6-50	15000 rpm	24953 ×g	50ml round bottom tube	3g /tube
8	FA15K	TA15-20-5	15000 rpm	23218 ×g	5ml round bottom tube	1g /tube
9	FA15L	TA15-30-2	15000 rpm	25507 ×g	2ml	1.5 g/ tube
10	FA14C	TA14-4-50T	14000 rpm	20926 ×g	50ml conical tube	3g /tube
11	FA14D	TA14-48-02	14000 rpm	20203 ×g	8*0.2ml tube	0.2g /tube
12	FA14E	TA14-48-2	14000 rpm	21123 ×g	2ml	1.5 g/ tube
13	FA11D	TA11-6-100	11000 rpm	13703 ×g	100ml	3g /tube
14	FA10C	TA 10-8-50T	10000 rpm	13147 ×g	50ml conical tube	3g /tube
15	FA8A	TA 8-4-250	8000 rpm	10210 ×g	250ml bottles	3g /tube
16	FA5A	TA5-12-5T	5600 rpm	4733 ×g	1 5ml	1.5 g/ tube
17	SW5MP	TMP5-2	4800 rpm	3103 ×g	96 well-plates	0.2 g / tube
18	SW5L	TS4-4-250L	4200 rpm	3550 ×g	250ml bottles	3g /tube
19	SW5	TS5-4-250	4800 rpm	4250 ×g	250ml bottles	3g /tube

\*: The imbalance tolerance given in the table indicate the mass imbalance or capacity imbalance when the centrifuge tubes are place symmetrically

\*\* : imbalance tolerance provide a rough measure of balancing and it is not necessarily to agree with mass imbalance.

Rotor parameters can also be viewed directly on the touch screen of the centrifuge. For details, see 4.8.7 Rotor catalog.

## 6.2 Cleaning and sterilizing tubes and bottles

1) 1) To choose optional conditions for cleaning and sterilizing the tubes and bottles, please refer to the following table.

Cleaning and sterilizing condition for tubes and bottles

O: Applicable; Not Applicable

Condition		PA	PC	PP	
Material					
Cleaning	Running water cleaning	Acidic detergent (pH 5 or lower)	X	X	X
		Acidic detergent (above pH 5)	O	O	O
		Alkaline detergent (above pH9)	O	X	O
		Alkaline detergent (pH 9 or lower)	O	O	O
		Neutral detergent (pH7)	O	O	O
		Warm water (up to 70°C)	O	O	O
	Ultrasonic cleaning	Neutral detergent (pH7)	O	O	O
Sterilization	Autoclaving	115°C ( 0.7kg/cm <sup>2</sup> ) 30 minutes	O	O	O
		121°C ( 1.0kg/cm <sup>2</sup> ) 20 minutes	X	O	O
		126°C ( 1.4kg/cm <sup>2</sup> ) 15 minutes	X	X	X
	Boiling	15–30 minutes	O	O	O
	UV sterilization	200–300nm	X	X	X
	Gas sterilization	Ethylene oxide	O	X	O
		formaldehyde	O	O	O

PA: Polyallomer; PC: Polycarbonate; PP: Polypropylene

### 2) Cleaning of PC centrifuge tubes and bottles

PC materials have low chemical stability against alkaline solutions. Avoid using detergents with pH higher than 9. Note that some neutral detergents' pH is still higher than 9 even if diluted according to the instruction. Use detergent with its pH between 7.0 and 9.0

### 3) Autoclave sterilization of PA, PC and PP centrifuge tubes

PA begins softening at about 120°C, and PC and PP at about 130°C. So disinfect PA tubes/bottles at 115°C (0.7kg/cm<sup>2</sup>) for 30 minutes and PC and PP tubes/bottles at 121°C (0.1kg/cm<sup>2</sup>) for 20 minutes when using the autoclaving. If the temperature is exceeded, the tubes/bottles may deform.

Please take the following instructions when using a sterilizing vessel:

- (1) Place bottles in vertical position with mouths upward. If bottles are inclined, they may deform due to gravity action.
- (2) Remove caps and inner covers to avoid deformation or rupture.
- (3) Take the bottles out when the sterilizing chamber cools down to the room temperature
- (4) Life span of centrifuge tubes and bottles

The life span of plastic centrifuge tubes and bottles depends on characteristics of sample, speed of the rotor, temperature and etc.

When plastic centrifuge tubes / bottles are used for ordinary centrifugation (pH 5.0 ~ pH 9.0), their lifespan is estimated as follows:

When operated at maximum speed:

High quality tubes and bottles (PA, PC, PP): 30~50 times

Ordinary tubes and bottles (PA, PC, PP): about 10 times

(use at low speed to increase the number of uses)

The life span of centrifuge tubes and bottles also depend on the treatment conditions such as cleaning and disinfection

**⚠ CAUTION:**

- Laboratory operators should dispose liquid waste and residue into the designated waste tank or container after each sample is separated by the centrifuge. This will facilitate efficient processing and recycling.
- Do not use cracked centrifuge tubes.

## 6.3 Noise of rotor operating at full load

This centrifuge adopts flexible shaft technology, and the noise level during full load operation of all rotary heads is low, reaching 53dBA, creating a quiet laboratory environment. The noise level of swing rotors (such as SW5L) and microplate rotor can reach 62dBA.

\* The above values are measured 1 meter directly in front of the centrifuge when the load is balanced, the centrifuge reaches the set temperature and maintains stable operating conditions.

\* If the load is unbalanced and the operating conditions are poor, the noise value may be different.

# 7. Centrifuge operation

## WARNING:

- Do not push or lean against the instrument while it is running. For your safety, do not step into the area within 30 cm around the centrifuge while it is running. Users are recommended to keep 30 cm away from the centrifuge when it is running.
- Do not run the centrifuge with fragments of tubes or dew drops left in the rotor chamber. Those matters may get mixed with samples or may cause the rise of the rotor temperature. Always keep the rotor chamber clean.
- If this centrifuge makes abnormal noise during its operation, stop it immediately and contact Dynamica service representative. Notify the error code if displayed.

## 7.1 Normal operation

- 1) Turn on the power switch. When the centrifuge is turned on the first time or the user lock is turned off:
  - The LCD lights up and displays the splash screen. After that the centrifuge performs initialization and self-test.
  - The 5 lights on the front panel light up and then go out.
  - If the centrifuge fails to pass the self-test, an error code will display and the 5 lights on the front panel will lights up simultaneously. Check the error message from the Table 11-1 and rectify the problem accordingly.  
**NOTE:** When the centrifuge is powered on, it takes approximately 7 seconds to perform initialization and self-test. The Status bar icon will refresh according to the equipment status.
  - The centrifuge will enter the stand-by mode and displays the last operating parameters after successful initiation and self-test.
  - Once the centrifuge passes the self-test, you can press the Open button on the touch screen to open the door lid. See Chapter 4.5 for details.
- 2) Gently lift the door and set the rotor on the drive shaft.
  - Make sure the rotor could contact the drive shaft completely and their pin does not overlap.
  - User should feel a click when the rotor is properly placed on the drive shaft. If you do not feel anything, there may be something (e.g. dusts) stuck between the rotor and the drive shaft and the rotor may be tilted. Check and clean the rotor or the shaft if needed.



- Rotate the rotor slightly and check it. If the rotor has obvious shaking, place the rotor again.
- 3) Close the door and the door lock will lock it automatically. Check and confirm that the door lock icon in the Status bar on the touch screen disappears.

**⚠ CAUTION:**

- Make sure that the angle between the door and the table is more than 70 degrees, otherwise the door may fall.
- Be careful not to get your fingers or hands caught between the door and body when closing the door.

- 4) Set the operating parameters

Refer to Chapter 4.1 for details. If you want to set and change the timing method, please refer to 4.8.1.5 .

**⚠ WARNING: Some buckets and adapters, and tubes, bottles and microplates that are sold on the market have lower allowable speeds (allowable RCF) than the rotor. Use them at the lowest allowable speed or less.**

- 5) Start operating: the 5 lights on the front panel light up and cycle from left to right, forming a moving light effect.

Refer to Chapter 4.6 for details. If there is anything wrong with the centrifuge, it will brake automatically and display the error number on the right bottom of the screen. The user can look up the error in Table 11-1 and make corrective actions accordingly.

**⚠ WARNING: Do not open the door before the rotor stops.**

**NOTE:** The centrifuge may shake slight when it is operated under 3,000 rpm, this does not indicate any problem.

- 6) End the run

The centrifuge will brake to stop when it reaches the end of running time or Stop button is pressed. Voice or Music prompt will play when the rotor stops completely.

## 7.2 Relative centrifugal force (RCF) operation

The maximum radius of each rotor is programmed in the memory of the centrifuge. User can run the centrifuge by simply entering the desired RCF ( $\times g$ ) and the ID code of the rotor.

All operations are the same as 7.1. You only need to select g (relative centrifugal force) mode when setting the speed.

## 7.3 Program operation

This centrifuge has 100 groups of parameters in its memory and all these parameters can be recalled directly. This function can help to save the parameters that are commonly used.

Refer to Chapter 4.2 for details of program saving, program selection, program deletion and other operations.

## 7.4 Pre-cooling operation

Refer to Chapter 4.4 for detailed operations.

NOTE: Pre-cooling generally refers to the chamber temperature. Rotor and sample usually pre-cooled in a refrigerator. Longer time is required if pre-cooling the rotor and sample by the pre-cooled function of the centrifuge.

## 7.5 Fast-Spin operation

Turn on the power switch and set the rotor on to the drive shaft. Check the set speed and change it when necessary. Refer to Chapter 4.5 for detail operation of Fast-spin operation. Press and hold the Fast-spin button on the touch screen. The rotor continues to accelerate while pressing this button, and when the centrifuge reaches the set speed, it will continue to operate at the set speed.

## 7.6 Operation records

The centrifuge can record and store 1,000 sets of historical data automatically. User can review the operating parameters when necessary. For specific operations, Refer to Chapter 4.8.5 for detail operation.

## 7.7 Data export

User can export the running records from the centrifuge by plug-in a USB disk and then export the data to the USB disk. Refer to Chapter 4.8.6 for detail operation.

## 7.8 User management

User management functions, including user creation, user query, change of user information, permission management and other related operations is added to this centrifuge. Refer to Chapter 4.8.1.3 for detail operation.

**NOTE:** 100 users can be created

If an user has not been created and the user lock is turned on, after powering on the equipment, the user has to log in to use the equipment. User can log on with the default user with below information.

Username: user01

Password: 676872

## 8. Acceleration and deceleration rates

The user can select from 10 acceleration rate (1-11) and 11 deceleration rate (0-11) to run the sample separation. Acceleration and deceleration rate are differed only in the speed from 0 rpm to 1000rpm. Figure 8.1 is shown as follows:

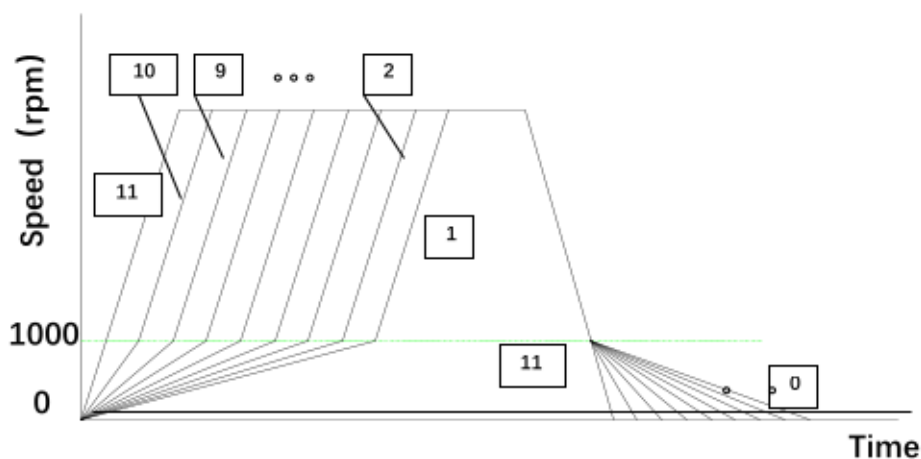

Figure 8.1 The schematic diagram of acceleration and deceleration curves

### Advice for Selection of Acceleration and deceleration Rates

- For pelleting samples, you can choose both acceleration rate 11 and decelerate rate 11 for efficient separation.
- To avoid sample disturbance or density gradient centrifugation deceleration process, you can choose a lower deceleration rate curve such as 6, 5, 4, 3.
- To separate invisible samples, such as DNA in microtubes, it is recommended to use accelerate and decelerate rate curves 9 and 10 respectively.
- When using a large-capacity rotor for centrifugal separation, try to use the 10 or 11 accelerate and decelerate rate curve 10 or 11 to avoid running in the resonance area for a long time, which will affect the separation performance and life span of the equipment. (Large capacity rotor: FA11D, FA8A, FA10C, SW5L, SW5, SW5MP)

Refer to 4.1.4 for the operation of acceleration and deceleration rate selection.

## 9. Temperature control

Temperature of the sample is controlled by detecting the rotor temperature through the temperature sensor. This centrifuge will automatically compensate for changes in temperature due to difference of rotors, based on the ID code and the speed of the rotor in use. Operator only needs to set the desired temperature and let the centrifuge optimize its temperature control.

### 9.1 Sample temperature during centrifugation

⚠ **CAUTION:** When a rotor at room temperature is used under the low set temperature, it will take a longer time to reach the set value. Some temperature sensitive samples may lose activity during this time. So, it is necessary to cool the rotor by pre-cooling function before loading this sample in the rotor. Pre-cool the rotor according to Chapter 7.4.

Changes in sample temperature during operation may vary depending on the rotor type and if the rotor is pre-cooled or not. Although the centrifuge displays the sample temperature, there is still a difference between the actual temperature of the sample and the displayed temperature, especially after centrifugation for a short period of time. Rotor pre-cooling is highly recommended to keep the sample temperature consistent with the displayed temperature or you need to spin at longer period.

\* When spinning the FA15G rotor at 4°C, please fully pre-cool (pre-cool for at least 90 minutes) to achieve the set temperature during centrifugation.

## 9.2 High temperature centrifugation

⚠ **CAUTION:** Running a rotor with a temperature set between 30°C and 40°C may deform the tubes or bottles as they are softened by high temperature. Before centrifugation, the centrifuge tubes and bottles should be tested under the same condition to ensure they do not melt or deform.

Since this centrifuge is not equipped with a heater, friction heat caused by the rotating rotor is utilized to increase the rotor (sample) temperature. Therefore, the desired temperature may not be reached due to low heat quantity even if the temperature is set above the room temperature if the set speed is too low.

# 10. Maintenance

## 10.1 Daily maintenance

△ **CAUTION:** If hazardous spill inside the centrifuge, the user must clean and disinfect the centrifuge according to the centrifuge decontamination procedures in this manual. Failure to clean or disinfect the centrifuge as recommended may damage the equipment. Before using non-recommended cleaning and disinfection methods, users should consult our company to ensure that the method will not damage the centrifuge. Please switch off the centrifuge before cleaning.

### 1) Centrifuge

- If the centrifuge is exposed to UV light for a long time, the color of the casing will change and the labels may be peeled off. Please cover the centrifuge with a cloth when not in use to avoid exposure to light.
- If the centrifuge is heavily stained, clean it with a cloth or sponge moistened with a neutral detergent solution.
- Sterilize the centrifuge by wiping with a cloth moistened with 70% ethanol solution.

### 2) Centrifuge chamber

- Wipe off the frost in the chamber with a soft cloth to prevent it from staining the sample or eroding the chamber. If the rotor chamber is dirty, clean it with cloth or sponge moistened with a neutral detergent solution.
- If dew drops are staying in the centrifuge chamber, dry the chamber with a soft cloth.

△ **WARNING: Do not pour water and other solvents directly into the centrifuge chamber. Otherwise, these solvents may enter the drive unit and cause bearing corrosion or damage.**

### 3) Drive shaft

- Wipe the drive shaft with soft cloth and then apply a thin layer of silicone grease on it.

### 4) The door

- To dry the centrifugal chamber, let the door lid open after use.
- Clean and sterilize the door using the same method specified in step 1).

## 6) Rotor

- To prevent corrosion, please remove the rotor from the rotor chamber after use. If a rotor is equipped with a cover, detach the cover and invert the rotor to dry the tube holes.
- If a sample is leaked in the rotor, first rinse the rotor with water, and then apply a small amount of silicon grease to it when it is completely dried. (Purchase the silicone grease separately.)  
(When separating microbial organisms, please pay attention to the warnings in the preface of this manual and Chapter 6. If the centrifuge and rotor are contaminated, or there is a potential risk of contamination, please follow the centrifuge cleaning and disinfection procedures listed in Chapter 10.2)
- For the use and maintenance of the rotor, please refer to the rotor instruction manual.
- The power cord should be inspected frequently. If any abnormality such as aging, coking and deterioration is found, notify the maintenance personnel promptly for replacement. The power socket must be installed securely and properly grounded.

## 10.2 Cleaning and disinfection

When separating microorganisms, use sealed tubes, sealed rotors, or biosafety buckets. Make sure all O-ring and seals are in place and in good condition before use. After separation, wait 5 minutes before opening the centrifuge lid and follow below steps:

1. If the centrifuge is found to be contaminated after opening the lid, the lid should be carefully closed again and all persons should leave the laboratory for at least 30 minutes. Post warning sign on laboratory doors.
2. If an accident occurs during centrifugation, the centrifuge power or emergency switch should be turned off, the lid should be kept closed. All personnel should leave the laboratory. Wait for at least 30 minutes for the aerosol to settle. Post warning sign on laboratory doors.
3. Remove all contaminated protective clothing and dispose of it into biohazard waste bin. Wash hands and all exposed skin with soap and water.
4. Notify laboratory supervisor.
5. Clear the area of contamination after 30 minutes. Wear personal protective equipment and carry spill cleanup tools into the laboratory. Wear full face protection mask, lab coat, and general-purpose gloves.
6. Transfer the rotor and bucket to the biosafety cabinet. Soak in 75% ethanol or a non-corrosive disinfectant that effective on the biological substances. It is recommended to soak for one



hour. After soaking, use disinfectant to wipe the uncapped or broken centrifuge tubes into another container. Use tweezers to pick up broken glass into a sharp objects waste bin.

7. Use tweezers to carefully remove the broken glass from the centrifuge and place it in a sharp object waste bin. Tiny broken glass can be collected with tweezers covered with cotton or paper towels. Carefully wipe the inside of the centrifuge with paper towels soaked in appropriate disinfectant. Spray the interior of the centrifuge with appropriate disinfectant and allow to air dry. Avoid using sodium hypochlorite because sodium hypochlorite solution is corrosive.
8. Place contaminated items in biological waste bags for disposal. Autoclave all the disposable personal protective equipment disinfection before disposal.
9. Wash hands with antiseptic soap and water.

### 10.3 Routine inspection and replacement of consumables parts

No.	Consumable parts	Frequency of inspection	Replacement conditions
1	Centrifuge chamber sealing ring	6 months	There are cracks and aging on the surface
2	Door seal	6 months	There are cracks and aging on the surface
3	Temperature sensor rubber sleeve	6 months	There are cracks and damage on the surface
4	Lock hole rubber pad	6 months	Seal ring deformation, damage, aging
5	Rotor cover o-ring	6 months	Seal ring deformation, damage, aging
6	Rotor seal	6 months	Seal ring deformation, damage, aging

The above is a list of consumables parts for the centrifuge. The consumables parts in the table must be those provided by our company.

**⚠ WARNING: This centrifuge is prohibited from separating materials containing hazardous substances such as toxic, radioactive, or contaminating substances. You cannot rely solely on sealing rings as the only way to protect operators and the environment. When centrifuging microorganisms, you cannot rely solely on sealing rings as protection as the only way to protect operators and the environment.**

# 11. Troubleshooting

## 11.1 Common malfunction list

The centrifuge is built with a self-diagnosis function. When the centrifuge fails and cannot run, the error code is displayed on the right side of the Home screen, and the five lights on the front panel flash together until the fault is resolved. You can easily spot the root cause of the failure.

**⚠ WARNING: Do not open the door lid when the rotor is still rotating.**

Table 11-1 Common malfunction, error code and solution

Symptom	Possible Causes	Solution	
Power on, no display	<ul style="list-style-type: none"> <li>·Power socket blackout.</li> <li>·The fuse is blown</li> </ul>	<ul style="list-style-type: none"> <li>· Remove the trouble and power again</li> <li>·Replacement insurance</li> </ul>	
The error code Exx is displayed on the screen	E-02 Door Open	<ul style="list-style-type: none"> <li>·Door opens while the rotor is rotating</li> <li>·Press Start button while the door is open</li> <li>·Door lock sensor failure</li> </ul>	<ul style="list-style-type: none"> <li>·Close the door immediately</li> <li>·Close the door and press Start button</li> <li>·Replace door lock sensor and wire components</li> </ul>
	E-03 Rotor ID	<ul style="list-style-type: none"> <li>·The rotor is not suitable for this centrifuge</li> <li>·Rotor identification sensor failure</li> <li>· Rotor is not in place</li> </ul>	<ul style="list-style-type: none"> <li>·Replace the rotor</li> <li>·Replace sensor</li> <li>·Reposition the rotor</li> </ul>
	E-04 Temperature Control Error	<ul style="list-style-type: none"> <li>·Insufficient cooling capacity</li> <li>·The air inlets and vents blocked</li> <li>·The radiator accumulates dust</li> <li>·Damage to refrigeration components</li> </ul>	<ul style="list-style-type: none"> <li>·The ambient temperature is too high. Lower the ambient temperature</li> <li>·Clear inlets and vents</li> <li>·Clean radiator</li> <li>·Replace damaged parts</li> </ul>
	E-06 Over Setting Speed	<ul style="list-style-type: none"> <li>·The set speed exceeds the maximum speed allowed by the rotor</li> </ul>	<ul style="list-style-type: none"> <li>·Re-set the speed setting value</li> </ul>
	E-08 No Rotor	<ul style="list-style-type: none"> <li>·No rotor is placed</li> <li>·The rotor is not placed correctly</li> <li>·The rotor identification signal is missing</li> </ul>	<ul style="list-style-type: none"> <li>·Reposition the rotor</li> <li>· Reposition the rotor</li> <li>·Check the rotor magnets and rotor identification signal cable</li> </ul>
	E-09 Imbalance	<ul style="list-style-type: none"> <li>·The imbalance of the rotor exceeds the allowable range</li> <li>·The centrifuge is shocked during operation</li> <li>· The centrifuge is placed on an uneven table</li> <li>· The rotor is not placed in the correct position</li> </ul>	<ul style="list-style-type: none"> <li>·Weigh the sample with a balance to ensure that the imbalance is within the allowable range</li> <li>·Do not push the equipment when it is running</li> <li>· Adjust table level</li> <li>· Reposition the rotor</li> </ul>
	Other fault codes	<ul style="list-style-type: none"> <li>·Contact after-sales</li> </ul>	<ul style="list-style-type: none"> <li>·Contact a service representative</li> </ul>

**NOTE:** Error codes E-01 to E-09 are mainly related to mis-operation. User can continue using the centrifuge after the malfunction is removed.

## 11.2 Error code query

The equipment has an error code query function. For detailed operations, please refer to Chapter 4.8.4.

## 12. Frequent problems and solution

### 12.1 How to open the door lid

#### 1) When power is on

**NOTE:** The door can only be opened when the centrifuge is powered on and the rotor is not rotating.

- While the centrifuge is powered on, press the Open button on the Home screen to open the door. The door lock is unlocked, and you can lift the door lid. The door lock will automatically lock door after about 3 seconds if it is not lifted by 3 seconds after unlocked.

**NOTE:** When the press the Open button, you will hear the click sound that indicates the door lock is unlocked. Please lift the door lid after the click sound. After a certain period of time (about 3 seconds), the door lock will reset and locked if the door lid is not lifted. (another click sound indicates the door lock is locked).

#### 2) In case of power outage

If the door cannot be opened due to the power outage, try to use the following steps:

##### (1) Make sure the rotor is not rotating

- Listen carefully to make sure that no sound can be heard.
- Confirm that the rotor is not rotating through observation window.
- Please allow sufficient time (20 minutes for large rotor) to let rotor to stop completely before taking any further actions.

##### (2) Insert a screwdriver into the small hole to open the door.

- The small hole is on the top of the left of the centrifuge which is covered by black rubber plug.
- Remove the black rubber plug.
- Insert a screwdriver to push the lock to open the door.

##### (3) While the screwdriver is pushing the lock, you can lift the door by hand.

## 12.2 How to remove the rotor stuck to the shaft

If the rotor is placed on the shaft for a long time, or due to extensive vibration, the rotor may stick to the shaft and will be difficult to remove it. Under this situation, the shaft may be bent if improper operation of the centrifuge.

Correct procedures as following:

- 1) Fix the screw (comes with accessory box of the centrifuge) into the central thread hole of the rotor.
- 2) Insert the screwdriver into the thread hole of screw. With one handing the rotor and other hand turn the screw right so that the screw can go down and touch the top of drive shaft.
- 3) Continue screwing the bolt down and the rotor will be lifted up from the driving shaft.
- 4) Remove the rotor with both hands and put the rotor on a horizontal table.
- 5) Turn the screw left and remove it from the rotor.
- 6) Inspect the drive shaft and the rotor. If any scratch is observed on their inner surface, please contact the service representative.

⚠ **CAUTION:** In case of rotor is stuck to the driving shaft, it is not allowed to remove the rotor using force. Otherwise, the drive shaft may be bent or damaged. User should remove the rotor following the above procedure.

⚠ **WARNING:** Users must follow this chapter to operate the centrifuge appropriately. **When the rotor is running, no matter whether it is powered on or off, the door lid cannot be opened with any tools. Under normal use, the effective life span of the interlocking protection devices of this centrifuge is 15,000 times.**

## 12.3 Door lock cannot be locked

Microswitch is used for the door lock of this centrifuge. After the door lock is opened, the microswitch motor needs to be reset before it can be closed. In case the microswitch is not yet reset and the power is suddenly cut off, then the door lock cannot be closed by pressing the door after the power is turned on again. Under this situation, while keeping the centrifuge power on, press Open button on the Home screen, and then press the door to close after hearing the click sound of the microswitch for resetting.

## 13. Rotating radius of applicable rotors

Table 13.1 Rotating radius list of rotors

No.	Rotor	Name	Velocity18R Plus		Maximum radius (cm)
			Maximum speed (rpm)	Maximum RCF (×g)	
1	FA18B	TA18-18-2	18000 rpm	24994 ×g	6.90cm
2	FA18C	TA18-10-10	18000 rpm	30318 ×g	8.37cm
3	FA15A	TA15-24-2	15000 rpm	21658 ×g	8.61cm
4	FA15D	TA15-4-100	1 5000 rpm	2 0878 ×g	8.30cm
5	FA15E	TA15-12-5T	15000 rpm	22639 ×g	9.00cm
6	FA15G	TA15-6-50T	15000 rpm	25004 ×g	9.94cm
7	FA15H	TA15-6-50	15000 rpm	24953 ×g	9.92cm
8	FA15K	TA15-20-5	15000 rpm	23218 ×g	9.23 cm
9	FA15L	TA15-30-2	15000 rpm	25507 ×g	10.14cm
10	FA14C	TA14-4-50T	14000 rpm	20926 ×g	9.55 cm
11	FA14D	TA14-48-02	14000 rpm	20203 ×g	9.22cm
12	FA14E	TA14-48-2	14000 rpm	21123 ×g	9.64cm
13	FA11D	TA11-6-100	1 1000 rpm	15584 ×g	11.52 cm
14	FA10C	TA 10-8-50T	10000 rpm	13147 ×g	11.76cm
15	FA8A	TA 8-4-250	8000 rpm	10210 ×g	14.27cm
16	FA5A	TA5-12-5T	5600 rpm	4733 ×g	13.5cm
17	SW5MP	TMP5-2	4800 rpm	3103 ×g	12.05cm
18	SW5L	TS4-4-250L	4200 rpm	3550 ×g	18cm
19	SW5	TS5-4-250	4800 rpm	4250 ×g	16.5cm

## 14. Calculation of relative centrifugal force (RCF)

Relative centrifugal acceleration (RCF) can be calculated using the following calculation formula.

$$\text{RCF} = 1.118 \times r \times N^2 \times 10^{-5}$$

$r$  - radius of rotation, unit: cm;  $N$  - rotation speed, unit: rpm

## 15. Replacement of fuse

The entire electrical part consists of filter, main control board, display panel , rotor identification sensor, USB board, LED board, vibration sensor, temperature sensor, motor, compressor, cooling fan, etc. The electrical part has two replaceable fuses, F8 and F9 , both of which are on the main control board and marked accordingly.

The electric system consists of filter, control board, drive board, display board, rotor identification sensors, USB board, LED board, vibration sensor, temperature sensor, motor, compressor, cooling fan and etc. There are two replaceable fuses, F8 and F9 in the electrical system, both are on the main control board and marked accordingly.

F9: F10AL250V,  $\Phi 5 \times 20$  mm, delay type, used for main circuit protection

F8: F8AL250V,  $\Phi 5 \times 20$ mm, delay type, used for compressor and fan protection

- △ Unauthorized repairs, disassembly, and other services to the centrifuge are strictly prohibited.
- △ Use the fuses provided by our company.



# 16. Guarantee

## 1. Guarantee of the centrifuge

This centrifuge is guaranteed (under normal maintenance) for one year from the date of delivery or no more than 18 months from the date of shipment (whichever comes first).

## 2. Guarantee of the rotors

The rotor is guaranteed for 2 years from the date of delivery. Pay extra attention not to use the rotor when it has been damaged by corrosion or material.

We do not guarantee the centrifuge and the rotor under the following conditions even before the guarantee period expires:

- (1) Damage caused by incorrect installation
- (2) Damage caused by incorrect operation
- (3) Damage caused by relocation or transportation after installation
- (4) Damage caused by unauthorized disassembly or modification
- (5) Damage caused by using non-Dynamica components such as rotors, buckets, adapters, etc.
- (6) Damage due to natural disasters, including fire, earthquake, etc.
- (7) Consumable parts and parts with a limited guarantee period

## **17. After-sales service**

Periodic maintenance is recommended to assure safe and efficient operation. If the centrifuge has something wrong, do not attempt to repair it by yourself. Contact our sales or service representative.

## **Dynamica Scientific Limited**

**A Techcomp company**

**Website: [dynamica-sci.com](http://dynamica-sci.com)**

**Kirkton Campus, 4 Bain Square, Livingston, United Kingdom**

**Postal code: EH54 7DQ**

**Tel: +44(0)1908 211 900**

**Fax: +44(0)1908 211 909**

**Email: [enquiry@dynamica-sci.com](mailto:enquiry@dynamica-sci.com)**