

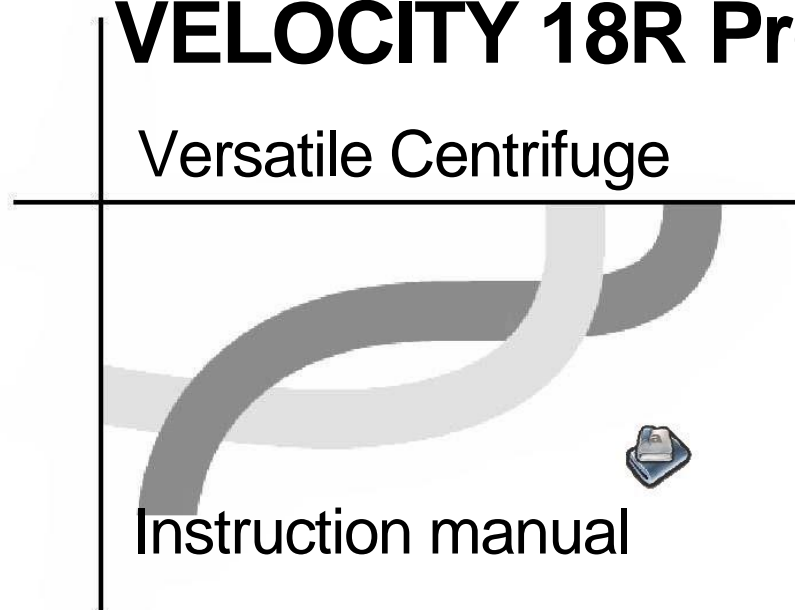

VELOCITY 18R Pro

Versatile Centrifuge



Instruction manual

Model VELOCITY 18R Pro Versatile Centrifuge

V 1.0

MODEL VELOCITY 18R Pro VERSATILE CENTRIFUGE

Thank you very much for purchase Dynamica Velocity 18R Pro Centrifuge. For efficient and safety operation, please carefully read this instruction manual before using Velocity 18R Pro, and keep all the handbook of this instrument carefully.





Appearance or specification is subject to change without notice.

Dynamica

Safety Reminder

Symbol  is the general internationally safety sign, please read carefully and fully understand the following safety precautions.

- Carefully read all safety messages in this manual and the safety instructions on the equipment.
- Safety messages are labeled as followings. The safety symbol  is in combination with words of “WARNING” and “CAUTION” to notify users the potential danger; The definitions of this two combination are as follows:

 **WARNING:** Personal dangerousness

Warning notes indicate any condition or practice, which if not strictly observed, could result in personal injury or possible death.

 **CAUTION:** Possible damage to equipment

Caution notes indicate any condition or practice, which if not strictly observed or remedied, could result in damage or destruction of the equipment.

NOTE: Notes indicate an area or subject of special merit, emphasizing either the product's capability or common errors in operation or maintenance.

- Do not use the centrifuge in the way which does not mention on this manual, Please contact Dynamica technician if you have any question.

 Safety Reminder

 **WARNING:**

- This centrifuge is not explosion-proof. Never use explosive or flammable samples.
- Do not install the centrifuge in or near places where inflammable gases are generated or chemicals are stored.
- Make sure to prepare necessary safety measures before using samples that are toxic, radioactive or contaminated with pathogenic micro-organisms.
- If the instrument, the rotor, and or accessories that has been contaminated by solutions with toxic, radioactive or pathogenic materials, clean it according to the decontamination procedure that you specified.
- If the contaminated equipment requires services of DYNAMICA or authorized agency of DYNAMICA, either at the customer's site, DYNAMICA or at the agent facilities, sterilize and decontaminate it in advance. Make sure to notify the service representatives of the use of such materials.
- Do not handle the power cord or turn on or off the POWER switch with wet hands to avoid electrical shocks.
- Users or any hazardous materials are recommended to keep 30cm away from the centrifuge when it is operating.
- While the rotor is rotating, never override the door lock.
- Unauthorized repairs, disassembly, and other services maintenance applied to the centrifuge except by our service personnel are strictly prohibited.
- When this product encounters disturbance of severe electrostatic discharge or surge, it might have some degradation of performance like resetting or random errors and so on. The operator should restart the equipment to recover the normal operation.
- This is a class A product. In a domestic environment this product may cause radio interference in which case the user may be required to take adequate measures.

 **CAUTION:**

- The centrifuge must be located on a firm and level table.
- Be careful not to get your finger or hands caught between the door hook and the table when closing the door.
- Do not move or relocate this centrifuge while the rotor is rotating.
- If dew drops found in the rotor chamber, drain out the fluid through the drain hole to prevent the sample to get mixed up with them and prevent them from leaking into the drive unit.
- Keep the chamber clean and remove any objects before running the instrument.
- Cautions on rotors:
 - 1) Always check for corrosion and damages on the rotor surface before using it. Do not use the rotor or bucket if such abnormality is found.
 - 2) Do not run this centrifuge over the allowable maximum speed of the rotor, buckets, and adapters. If their maximum speeds vary, run it at the lowest maximum speed among them.
 - 3) Do not exceed the allowable imbalance tolerance.
 - 4) Make sure the tubes and bottles within their actual capacities.
 - 5) Make sure all the buckets are the same type at all times.
 - 6) If the rotor is provided with a cover, make sure it is tightly rotated on the rotor before the operation.
 - 7) Use recommended rotors only. If any abnormal condition occurs during operation, stop it immediately and contact our service representative. Notify the service representative the error code.
- Earthquakes may cause damage to the centrifuge. Contact our service representative if abnormality observed.

Contents

1 Specification.....	1
2 Operational Condition.....	2
2.1 Basic operational conditions	2
2.2 Transport and storage condition.....	2
3 Installation	3
3.1 Location.....	3
3.2 Connection of the power cord and grounding	3
3.3 Horizon adjustment.....	4
4 Structure	6
5 Operation panel.....	7
6 Preparation (Rotor)	9
7 Operation.....	12
7.1 Normal Operation	12
7.2 RCF Operation	18
7.3 Programmed Operation	18
7.4 Pulse Operation	19
7.5 Pre-cooling operation	20
7.6 Browse the rotor information.....	21
8 Acceleration and Deceleration Rates.....	22
9 Temperature Control.....	23
9.1 Sample temperature during the run	23
9.2 High-temperature operation	23
10 Maintenance	24
10.1 The daily maintenance.....	24
10.2 Consumable Parts	25
11 Troubleshooting.....	26
11.1 Common malfunction list	26
11.2 Identify the malfunction	27
12 Frequent problems and solutions	28
12.1 How to open the door.....	28
12.2 How to remove the rotor stuck on the shaft.....	28
13 List of applicable rotors and tubes	30
13.1 Table of applicable rotors.....	30
13.2 Cleaning and sterilizing tubes and bottles	32
14 Rotating radius of applicable rotors	34
15 Calculating (RCF)	34
16 Fuses	35
17 Guarantee	36
After-sales Service	36

1 Specification

Maximum speed	18,000rpm
Maximum RCF	28,978×g
Maximum capacity	1L (4×250ml)
Timer	1Minute~99hours59Minutes~HOLD function
Settable temperature range	-20°C~40°C
Acceleration/deceleration profiles	(1~9) / (0~9) (9 is the fastest curve)
Driving system	Inverted induction Motor
Refrigerant	R134a
Program memory	9
Safety features	Cover door with dual-locks, over-speed detector, over-heat detector and imbalance detector, automatic situation diagnosis system
Power requirements	220V: Single phase, ~220-240V±10%, 50/60Hz±1Hz, 1800VA
	110V: Single phase, ~110V±10%, 60Hz±1Hz, 1800VA
Dimensions (mm)	730mm×610mm×380 mm(L*W*H)
Weight	About 100kg
Additional features	Rotor auto identification, Speed/RCF switch, Pre-cooling function, Pulse operation, Processing display

2 Operational Condition

2.1 Basic operational conditions

1) Power: (220V) single phase, $\sim 220-240V \pm 10\%$, $50/60\text{Hz} \pm 1\text{Hz}$, 10A, standard sine wave;

(110V) single phase, $\sim 110V \pm 10\%$, $60\text{Hz} \pm 1\text{Hz}$, 25A, standard sine wave;

Install an emergency switch that turns off the main power supply in the event of malfunction. It is ideal to install the emergency switch outside of the room or near the exit;

2) Ambient temperature: $2^{\circ}\text{C} \sim 40^{\circ}\text{C}$;

3) Relative humidity: $\leq 80\%$;

4) No vigorous vibration and airflow around;

5) No electric dust, explosive and corrosive gases around;

2.2 Transport and storage condition

1) Storage temperature: $-40^{\circ}\text{C} \sim +55^{\circ}\text{C}$;

2) Relative humidity: $\leq 93\%$.

3 Installation

This section describes the instructions that you should abide by when installing the centrifuge. Before moving the centrifuge, the rotor must be removed.

WARNING:

- This centrifuge may be damaged if it is connected to an improper power source.
- Check if the power source meets the requirements specified on the plate at the rear of this centrifuge.

3.1 Location

- 1) Locate this centrifuge on a firm and level table, ensure the four feet of this centrifuge stand on the table firmly. Avoid installing on the slippery table otherwise the centrifuge will have a bigger vibration.
- 2) Ideal environment temperature is $20^{\circ}\text{C} \pm 5^{\circ}\text{C}$. Temperature should not be over 30°C . Avoid direct sunlight to the instrument.
- 3) Keep 300 mm distance on both sides and back of this centrifuge. This is a safe distance of the centrifuge. After installing, this distance should be marked around the centrifuge to ensure its cooling efficiency.
- 4) Make sure there is no water or heat around the centrifuge. Otherwise, it will result in sample's temperature increasing or malfunction of centrifuge.

 **WARNING:** No any hazardous materials are within 30cm around the centrifuge to avoid leaking due to heavy vibration of the centrifuge.

3.2 Connection of the power cord and grounding

WARNING:

- Do not touch the power cord with wet hands to avoid electrical shocks.
- This centrifuge must be properly grounded.

- 1) This centrifuge is equipped with a 3P flat plug, 1P of 3P is for grounding. Grounding can be done by plugging the 3P plug into the outlet.
- 2) The outlet must have bigger current capacity than 10A (for 220V instrument) or 25A (for 110V instrument), and its earth terminal is installed properly.

3.3 Horizon adjustment

1) Turn on the power switch. After initialization, open the cover and turn off the power switch. If the machine is not connected to the power supply, user may refer to the method explained in section 12.1, and then open the cover.

2) Put the Level on the axis crown (see the following figure), and revolve the axis crown for at least one circle and observe whether the air bubble is always in the central of the level to check whether the centrifuge is horizontal.

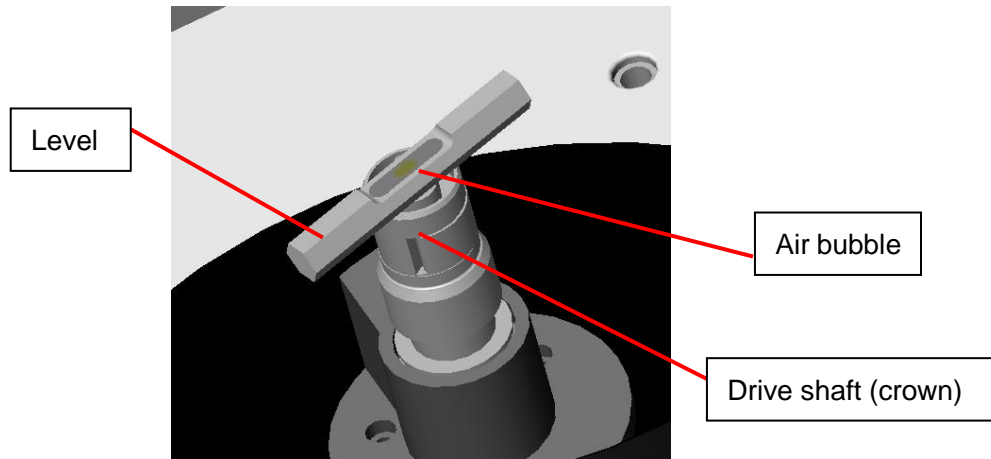

3) If the centrifuge is not horizontal, adjust the four support feet under the bottom plate (see the following figure) until the air bubble stay in the central of level. During adjustment, user should rotate the axis crown continuously and check the position of air bubble. To adjust the level, unscrew anticlockwise the lock screws to loosen them. Turn the support feet clockwise to lower the centrifuge, vice verse. (Use the wrench in the accessory box if needed.)

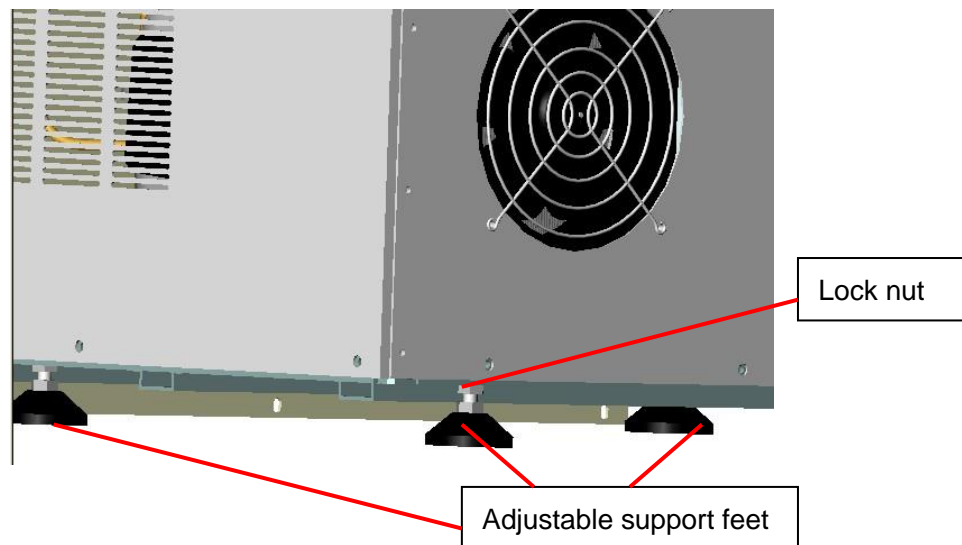

4) When the instrument is horizontal, make sure four support feet are firmly standing on the table. Any suspended support foot is not allowed. Slightly press the top of the

centrifuge for checking.

5) Tighten the screws of each support foot after adjustment.



CAUTION:

- Before moving the instrument, confirm that no rotor is installed on the drive shaft.
- Before operating the instrument, confirm that the centrifuge is level.

4 Structure

Front

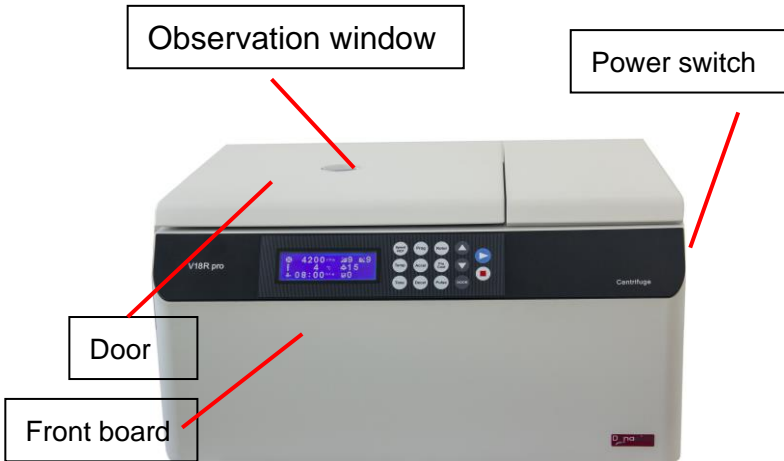

Rear

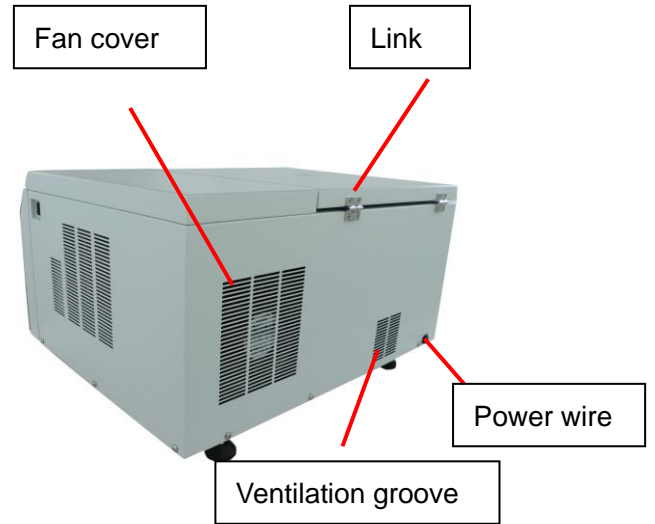

Inner



Chamber

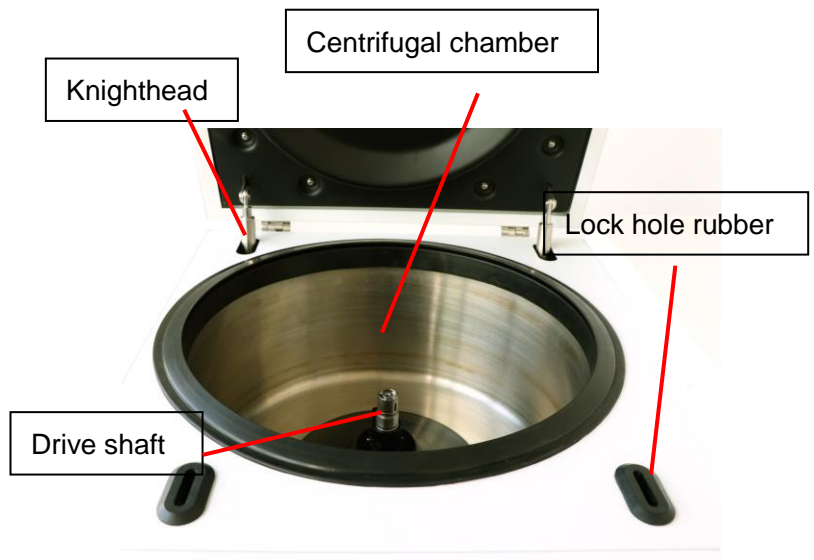

5 Operation panel

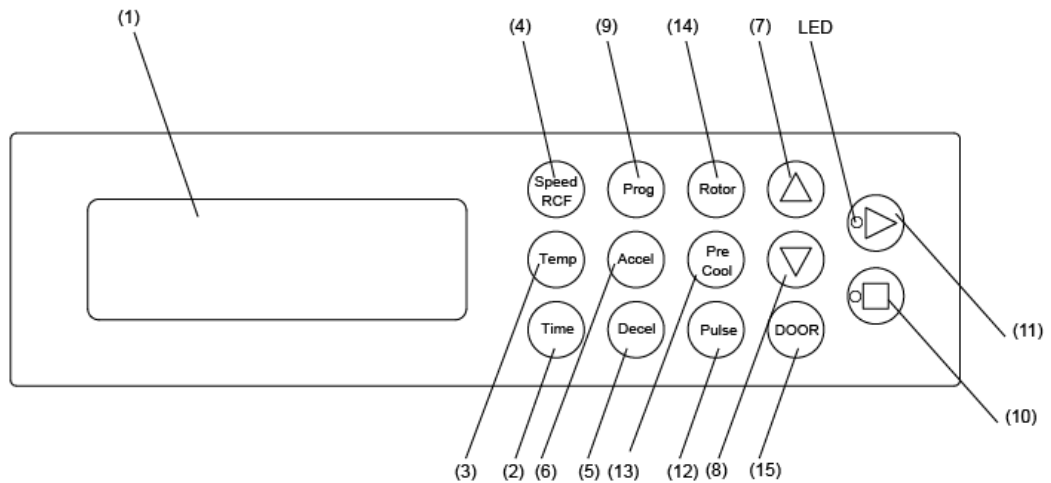







Figure 5-1 Operation Panel

NO.	Symbol	Name	Function
(1)		LCD Screen	Displays running parameters and state(Figure 5-2)
(2)		Time button	Set a running time (1min~99hours59min~HOLD)
(3)		Temperature button	Set a control temperature of the sample
(4)		Speed/RCF button	Set speed or RCF
(5)		Deceleration button	Set a deceleration rate.(0-9, 9 is the fastest)
(6)		Acceleration button	Set an acceleration rate. (1-9, 9 is the fastest)
(7)		Increasing button	Increase parameter values
(8)		Decreasing button	Decrease parameter values
(9)		Programmed button	Store and recall running conditions (0-9groups)

(10)		Stop button	Make the Rotor stop rotating. The red lamp blinks while decelerating and quenches when the rotor stops rotating.
(11)		Start button	Make the rotor start spinning. The green lamp blinks while accelerating and keeps lighting when the speed reaches the set value.
(12)		Pulse button	Accelerate the rotor while this button is pressed. The rotor slow down and stop while this button is released.
(13)		Pre-cool button	Press this button and turn into Pre-cooling mode.
(14)		Rotor button	Select the rotor number or inquire the rotor parameters
(15)		Door button	Door lock is released when this button is pressed.

LCD screen displays the main interface as figure 5-2. The left part shows parameters of the rotary speed, the temperature and the time. The right part shows the operation status of acceleration, deceleration, rotor ID and program group etc.

The interface displays the operation parameters when the rotor is running, these parameters can be modified only when the rotor stops or it reaches the setting point. Please refer Section 7 for detail.

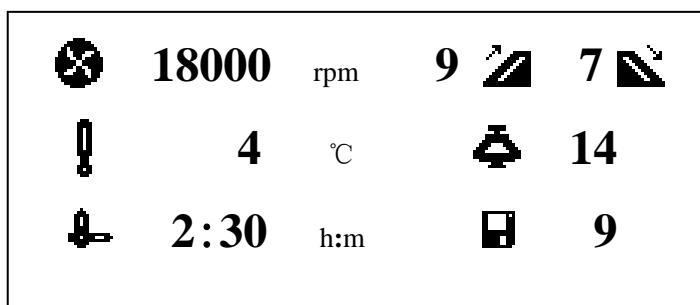

Figure 5-2 The LCD main interface

6 Preparation (Rotor)

⚠ WARNING:

- This centrifuge and the rotor are not explosion-proof. Never use explosive or flammable samples.
- There are restriction on the usage of biological samples and radioactive substances that require biological isolation such as pathogens and recombinant DNA for safety purposes. User must prepare necessary safety measures before treating with samples containing such substances.

1) Prepare the sample

2) Put the sample into tubes or bottles

⚠ CAUTION: Sample may leak from the gap between the bottle and its cap if the bottle is fully filled up.

- Do not exceed the capacity that is specified in the instruction manual.

3) Balance the centrifuge tubes or bottles

⚠ CAUTION: The samples with different composition but same volume have different sedimentation during centrifugation and will cause imbalance. Due to this, the sample with same composition should be placed symmetrically.

- See Table 6.1 or the rotor specification for imbalance tolerance of each rotor.
- Although this centrifuge can accept eye balancing sample, we recommend that the sample are well-balanced to prolong its service life.
- Never intentionally run the centrifuge under unbalanced condition even though the imbalance tolerance is not exceeded.

4) Inspect the rotor

⚠ CAUTION:

- If any abnormality such as corrosion or scratches is found, stop using the rotor and contact Dynamica service representative.
- Other brand or type of rotor is forbidden on the instrument.

- Check the rotor and the buckets for corrosion or scratch before use.
- Check whether the swinging bucket rotor swings smoothly by slightly spinning the rotor manually. Perform periodic maintenance on the rotor.

5) Set balanced tubes or bottles symmetrically on the rotor or rotor frame

⚠ CAUTION: Make sure that the cover is put on the rotor and fixed securely. Otherwise, the rotor or its cover may be dropped off while the instrument is running. That might damage the centrifuge or the rotor.

6) Confirm the ID code of the rotor

- This centrifuge can identify rotors automatically.
- Each rotor is assigned with an ID code. After the rotor is identified, the optimum temperature can be automatically obtained. And the function of over-speed protection and the speed/RCF display can be realized.
- The list of available rotor's ID code, see Table 6.1.

Table 6.1 List of rotors

No.	Rotor	ID	Max Speed (rpm)	RCF (×g)	Tube Capacity
1	FA18B	36	18,000	24,990	1.5/2ml
2	FA18C	01	18,000	28,978	10ml
3	FA15A	19	15,000	21,658	1.5/2ml
4	FA15B	16	15,000	21,835	50ml
5	FA15C	18	15,000	23,294	50ml
6	FA15D	17	15,000	20,900	100ml
7	FA15E	06	15,000	22,600	5ml V bottom
8	FA15F	04	15,000	22,600	5ml
9	FA15G	09	15,000	25,004	50ml V bottom
10	FA15H	21	15,000	24,950	50ml
11	FA15K	22	15,000	23,210	5ml
12	FA15L	23	15,000	25,516	1.5/2ml
13	FA14C	13	14,000	20,926	50ml V bottom
14	FA14D	11	14,000	20,203	0.2ml micro tube
15	FA14E	12	14,000	21,132	1.5/2ml
16	FA12A	03	12,000	14,100	0.2ml micro tube
17	FA12B	02	12,000	13,840	1.5/2ml
18	FA10B	20	10,000	11,400	50ml V bottom
19	FA5A	07	5,600	4,733	15ml
20	SW5	50	4,800	4,173	250ml bottle
21	SW5L	15	4,200	3,550	250ml bottle
22	SW5MP	55	4,800	3,120	96-well plate
23	SW4A	60	4,000	2,950	50ml V bottom

* : The imbalance tolerance given in the table indicate the mass imbalance or capacity imbalance when the centrifuge tubes are place symmetrically.

** : Capacity imbalance provide a rough measure of balancing and it is not necessarily to agree with mass imbalance.

7 Operation

⚠ WARNING:

- Never open the door while the rotor is rotating or touch the rotation rotor.
- For your safety, do not step into the area within 30 cm around the centrifuge while it is running. Users are recommended to keep 30 cm away from the centrifuge when it is running.

⚠ CAUTION:

- Do not push or lean against the instrument while it is running.
- Do not run the centrifuge with fragments of tubes or dew drops left in the rotor chamber. Those matters may get mixed with samples or may cause the rise of the rotor retention temperature. Always keep the rotor chamber clean.
- If this centrifuge makes abnormal noise during its operation, stop it immediately and contact our service representative. Notify the alarm code if displayed.

7.1 Normal Operation

1) Turn on the power switch.

- This centrifuge first starts a self-checking process. Then the LCD Screen displays a welcome interface (see Figure 7-1).

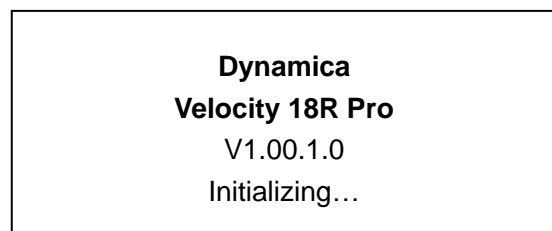

Figure 7-1 Initialization interface

- If the self-checking fails, the screen displays an error code on its right bottom corner. Refer the error code in the table 11-1.

NOTE: When the power switch is turned on, this centrifuge will take 7 seconds to self-check. During this time, the centrifuge will have no response to the buttons.

- This centrifuge will move to a preparing interface after self-checking, and display the running parameters of the last time. For example, the Figure 7-2 shows that the speed was set to be 18000rpm, the temperature was 4°C, the running time was 2 hours and 30 minutes, the acceleration rate was 9, the deceleration rate was 7, the rotor ID was 14, and the program group number was 9.

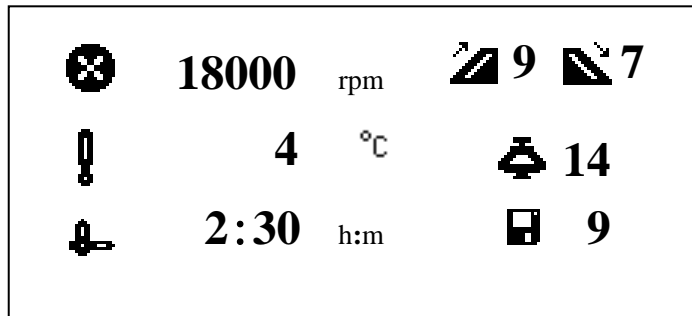



Figure 7-2 Preparation mode interface

- Open the door

After self-checking has passed, user can open the door by pressing  button. After 6 seconds, door lock will close automatically.

2) Gently lift up the door and set the rotor on the drive shaft.

 **CAUTION:**

- Make sure to use all the buckets when the swinging bucket rotor is used. Otherwise the rotor may be deformed during the rotating and the buckets may be moved off from the rotor.

- Make sure the rotor could contact the drive shaft completely and their pin does not overlap.

- User should feel a click when the rotor is properly placed on the drive shaft. If you do not feel anything, there may be something (e.g. dusts) stuck between the rotor and the drive shaft and the rotor may be tilted. Check and clean the rotor or the shaft if needed.

- Rotate the rotor slightly and check it. If the rotor has obvious shake, place the rotor again.

3) Close the door and start running.

 **CAUTION:**

- Be careful not to get your fingers or hands caught between the door hook and table when closing the door.
- Make sure that the angle between the door and the table is more than 70 degree, otherwise the door may fall down.

4) Set the operating parameter

⚠ CAUTION: Some buckets and adapters, and tubes, bottles and microplates that are sold on the market have lower allowable speeds (allowable RCF) than the rotor. Use them at the lowest allowable speed or less.

(1) Select a rotor ID.

① Press the  button.

■ The rotor symbol  blinks, the rotor ID can be selected.

② Press  or  button to select the rotor ID.

■ The rotor ID code is given in Table 6.1 or it can be obtained by rotor inquiring function (refer to 7.6 section).

NOTE: This step can be omitted because all rotors are automatically recognized.

(2) Set the speed, running time, sample temperature, acceleration and deceleration rate.

① Press  button.

■ Speed symbol  blinks.

When the speed unit is RCF, it indicates you can input required RCF value. Then, press the  button again, the speed unit becomes rpm, now user can input speed value. In the same way, user can also change rpm into RCF.





■ If no button is pressed after the symbol  has been blinking for 7 seconds, the symbol will stop blinking, close the inputting mode.

② Press  and  buttons to adjust the parameter.



















■ The minimum speed you can set is 300 rpm with the interval of 100rpm.

■ The minimum RCF you can set is 100xg with the interval of 50xg.

■ When keep pressing  and  buttons, you can set the values in a fast mode.

■ There is a cycling function on  and  buttons. When pressing the  button to the maximum value, it will return to minimum value, vice verse for pressing  button.

NOTE: The centrifuge may shake slight when it is operated under 2,600rpm, this does not indicate any problem.

- ③ Press the  button to set sample temperature.
- When the temperature symbol  blinks, the temperature is ready to be set.
 - Press  or  button to set the temperature value, the range is from -10°C to 40°C with the interval of 1°C.
- ④ Press  button to set running time.
- While the time symbol  blinks, the running time can be set.
 - Press  or  button to set the running time, the range is from 1minute to 99 hours and 59minutes~HOLD with the interval of 1 minute.
- ⑤ Press  button to set acceleration rate.
- While the acceleration symbol  blinks, the acceleration rate can be set.
 - Press  or  button to set the acceleration rate, the range is from 1 to 9 with the interval of 1. Curve 9 is the highest rate.
- ⑥ Press  button to set deceleration rate.
- While the deceleration symbol  blinks, the deceleration rate can be set.
 - Press  and  buttons to set the deceleration rate, the range is from 1 to 9 with the interval of 1. Curve 9 is the fastest rate.
- 5) Start running.
- (1) Press  button, to check the setting values again.
- Press  button, the screen displays the parameter verification screen (see the following interface)

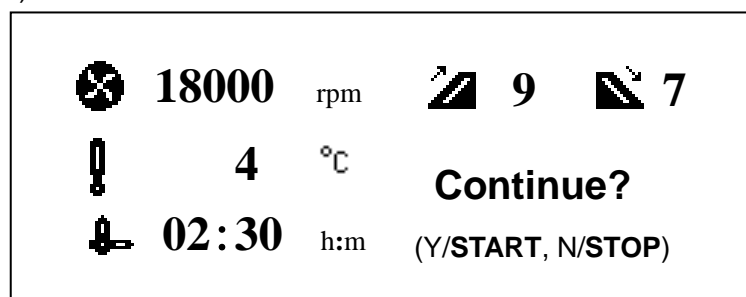



Figure 7-3 Verification of the operation parameters

- If something is wrong with the operation parameter, press  button, the centrifuge will return to the preparation mode for correction.

- If no button is pressed for 7 seconds, the centrifuge will return to the preparation screen.

(2) Press  button again, start running.

- The door should be locked before the rotor starts rotating.

- During the acceleration, the green lamp on  button keeps blinking. After the speed reaches set value, the lamp stops blinking and keeps lighting.

- After accelerating for 8 seconds, the interface will display the processing screen, see the Figure 7-4.

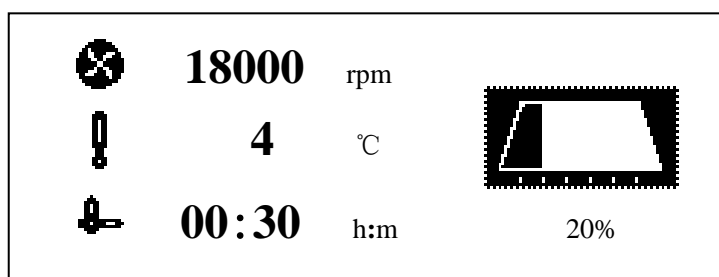

Figure 7-4 Processing Screen

- The processing screen displays the whole running process while the centrifuge operates.

The left part of this screen shows the actual running parameters, the time is the actual operation time, not including the acceleration time. The right part indicates the whole process of the acceleration stage, the stable stage and the deceleration stage. It also shows the running percentage. This screen makes it easier for the operator to monitor the whole running process.

The running status can not be shown in pre-cooling mode or pulse mode. Under the continuous running mode, the right part of this screen displays the waving bar and the HOLD symbol.

(3) Browse and modify the running parameters

- User can inquire and modify the operation parameters after the centrifuge reaches its setting speed. Press the corresponding button, the Screen will return to the preparation screen and displays all setting values. How to modify the parameters please refer to the section 7.1-4. This centrifuge will return to its normal operation and operate in new parameters if no button is pressed 6 seconds later.

■ The rotor ID couldn't be modified when the rotor is in operation. If the setting time has been modified, the operation time will not be clear but be continuous accumulated, and the processing screen will make corresponding adjustment.



(4) Error display

■ If there is anything wrong with the centrifuge, it will brake automatically and display the error number on the right bottom of the screen. User can look up the error in the Table 11-1 and make corrective actions accordingly.

 **WARNING:** Do not open the door before the rotor stops.

6) Ending the running

(1) The centrifuge will brake when it reaches the end of running time or  button is pressed.

■ As the rotor decelerate, the green lamp on  button turns off, and the red one on  button starts blinking.

■ When the rotor stops, the red lamp on  button stops blinking and turns off. The instrument beeps 4 times to remind users that the operation is finished.

(2) Open the door.

■ When the operation is finished, user can open the door by pressing  button.

■ After ending the operation, the centrifuge will save the operating parameters and recall them when power switch is turning on again.

NOTE: If  button is pressed before the operation time is over, the rotor will brake to stop at the highest deceleration rate.

(3) Take out the rotor or the sample.

 **CAUTION:** The rotor must be taken out if the centrifuge does not work. Otherwise, the rotor is likely to be corroded or to damage the drive shaft.

■ To continue using the centrifuge, close the door to prevent dew drops in the rotor chamber.

■ At the end of daily operation or if the centrifuge will not be used for a long time, open

the chamber door and turn off the power to dry the rotor chamber. User can close it when it is completely dry.

7.2 RCF Operation

The maximum radius of each rotor is programmed in the memory of the centrifuge. User can run the centrifuge by simply entering the desired RCF (xg) and the ID code of the rotor.

NOTE: Refer section 7.1-4, speed/RCF conversion, to set operating parameters.

1) Set a RCF.

⚠ CAUTION:

- Do not exceed the allowable maximum RCF of the buckets, adapters, and tubes/bottles.
- RCF is calculated with the maximum radius and the rotating speed.

(1) Set the RCF value.

① Press  button.

■ The Speed/RCF symbol  blinks.

■ When the symbol unit is rpm, it indicates you can input speed value. But press the

 button again, the symbol unit will shift to RCF, then you can input RCF value.

■ If no button is pressed after the symbol  having blinked for 4 seconds, the symbol will stop blinking, and the inputting mode will be closed.

② Press  and  buttons to set a RCF value.

■ The step size is 50 xg.

(2) Set running condition

Set running time, sample temperature, acceleration and deceleration rate according to 7.1-4 section.

7.3 Programmed Operation



This centrifuge has nine groups of parameter in its memory and all this parameter can be recalled directly. This function can help to save the parameters that are commonly used.



NOTE:

- Press  button to call and save programmed parameters.
- Newly programmed parameters will overwrite the old ones.

1) Programming the running parameters.

(1) Turn on the power switch and set the rotor onto the drive shaft.

(2) Press  button and the symbol  blinks. User can input serial number of program.

(3) Press  or  button to choose your desired program. The running parameters will display on LCD screen and change with the serial number.



(4) Modify the operating parameters please refer to section 7.1-4.

(5) Double press  button, and then the new parameters will be saved.

2) Recall programmed parameter.

(1) Turn on the power switch and set the rotor onto drive shaft.



(2) Press  button and the symbol  blinks, then the instrument enter a programmed running mode.

(3) Press  or  button to choose your desired parameter. The parameters will change with the serial number. The serial number is from 1 to 9 that is corresponding 1 to 9 group parameters respectively.

(4) Press  button to run the centrifuge, for details please refer to the section 7.1-5.

7.4 Pulse Operation

NOTE:

- Under this mode, the acceleration and braking speed is designed to run at maximum, regardless of the settings.
- The centrifuge accelerates up to the setting speed.
- If the  button is released during acceleration, the centrifuge will discontinue the acceleration and starts the deceleration.
- The  button works only when the rotor is stopped and when the door is locked.

1) Turn on the power switch and set the rotor onto the drive shaft.

2) Check the set speed and change it when necessary.

3) Press  button.

■ The rotor continues to accelerate while pressing this button, and when the centrifuge

reaches the set speed, it will continue to operate at the set speed.

4) Release  button.

- The rotor starts the decelerating process, until it stops.

7.5 Pre-cooling operation

■ This function is designed to improve the ability to control the sample temperature. Using this function, the operator can cool the rotor chamber and the rotor in advance.

1) Press  button, then the centrifuge displays pre-cooling screen.

- The pre-cooling screen is shown as figure 7-5.

2) Set the temperature and rotor ID.

■ For details please refer to section 7.1-4. The centrifuge will automatically choose the accelerating and decelerating rate according to the rotor ID in the pre-cooling mode. Only the temperature value and the rotor ID can be modified, other parameters can not be changed.

■ The centrifuge will return to the preparation mode if no button is pressed for 8 seconds.

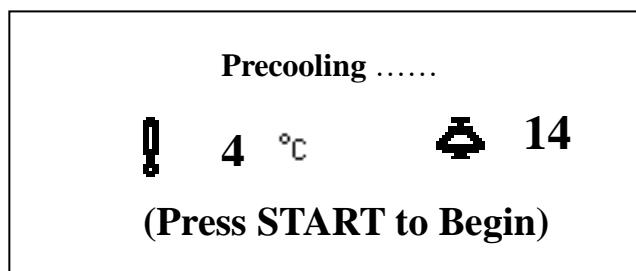



Figure 7-5 Pre-cooling interface

3) Close the door and press  button to run the centrifuge.

■ During the pre-cooling operation, the Figure 7-5 displays the operating temperature.

■ During the pre-cooling process, the instant rotating speed can be checked by pressing the  button. The value will display at left corner of the Screen and disappears 3 seconds later. And the instrument will return to the state of Figure 7-5.

■ Before starting the pre-cooling operation, press  button and the centrifuge can return to the preparation mode.

4) When the rotor reaches its setting temperature, the cooling process will stop and the centrifuge will beep and return to the preparation mode 5 seconds later.

■ If  button is pressed during the pre-cooling operation, the cooling process will



stop and the centrifuge will beep and return to the preparation mode.

5) Put samples into the rotor and run the centrifuge. (refer to section 7.1)

7.6 Browse the rotor information

1) Checking for the rotor information

In the preparation mode, press  button twice, the information of the current rotor will be displayed. See Figure 7-6, take rotor 14 for example.

- As a normal operation, set the rotor ID to be 14.
- Press  button twice, the rotor information is displayed, as shown in the Figure 7-6.
- The centrifuge will return to the preparation mode by pressing the  button.

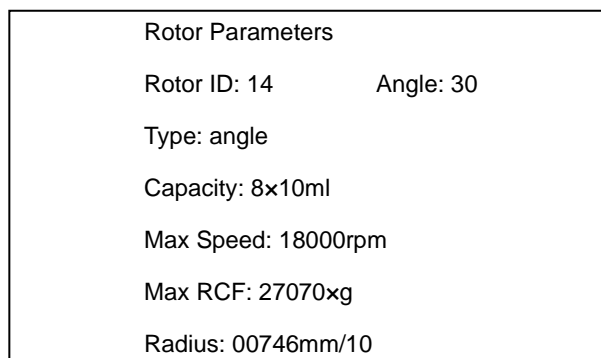

Figure 7-6 Browsing rotor parameters

Descriptions are as follows:

Rotor ID: 14;	Angle: 30°;
Type: angle rotor;	Capacity: 8x10ml;
Max Speed: 18000rpm;	Max RCF: 27070xg;
Max Radius: 74.6mm;	

2) Registering new types of rotors

The centrifuge can be registered for 3 extra new types of rotors. For safety concern, only the rotors equipped with the centrifuge are recommended to use, in case new types of rotors are needed, please contact our service representative.

8 Acceleration and Deceleration Rates

The user has 9 kinds of acceleration and deceleration rate to satisfy the sample separation. Acceleration and deceleration can be changed in the rate from 0rpm to 1000rpm. Figure 8.1 is shown as follows:

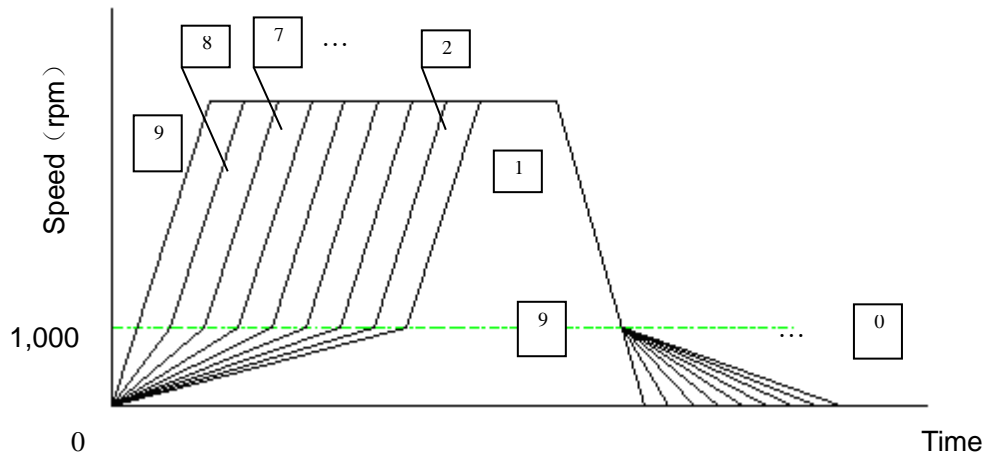

Figure 8.1 The schematic diagram of acceleration and deceleration curves

Advice for Selection of Acceleration and deceleration Rates

- To collect precipitate, it is recommended to set acceleration and deceleration grade at 9 to efficiently separate it.
- To avoid a disturbance during deceleration process, it is recommended to select the grade at 6, 5, 4 or 3.
- To separate invisible samples, such as DNA in microtubes, it is recommended to choose 7 or 8 grade of acceleration and deceleration rate.

9 Temperature Control

Temperature of the sample is controlled by detecting the rotor temperature through the temperature sensor. This centrifuge will automatically compensate changes in temperature due to difference of rotors, based on the ID code and the speed of the rotor in use. Operator only needs to set the desired temperature and let the centrifuge optimize its temperature control.

9.1 Sample temperature during the run

⚠ CAUTION: When a rotor at room temperature is used under the low set temperature, it will take a longer time to reach the set value. Some temperature sensitive sample may lose activity during this time. So it is necessary to cool the rotor by pre-cooling function before loading this sample in the rotor. Pre-cool the rotor according to the section 7.5.

Changes in sample temperature during operation may vary depending on the rotor type. Although the centrifuge displays the sample temperature, reading and actual difference may still arise e.g. in a short time operation; if the rotor used and the setting have significant temperature difference.

9.2 High-temperature operation

⚠ CAUTION: Running a rotor with a temperature set between 30°C and 40°C may deform the tubes or bottles as they are softened by high temperature. Perform test operation under the same conditions with the tubes or bottles to be used filled with liquid in advance, to ensure that it does not melt or deform.

Since this centrifuge is not equipped with a heater, friction heat caused by the rotating rotor is utilized to increase the rotor (sample) temperature. Therefore, the desired temperature may not be reached due to low heat quantity even if the temperature is set above the room temperature if the set speed is too low.

10 Maintenance

⚠ CAUTION: Using cleaning or sterilization methods other than recommended in this instruction manual may cause corrosion or deterioration to this centrifuge. Please switch off the centrifuge before cleaning.

10.1 The daily maintenance

1) Centrifuge

- If the centrifuge is exposed to ultraviolet rays for a long time, the color of the covers may be changed and the label may be peeled off. Please cover the centrifuge with cloth after use to avoid direct exposure.
- If the centrifuge is heavily stained, clean it with a cloth or sponge moistened with a neutral detergent solution.
- Sterilize the centrifuge by wiping with a cloth moistened with 70% ethanol solution.

2) Rotor chamber

⚠ CAUTION: Do not pour water or other solvent directly into the rotor chamber. Otherwise it may leak into the drive unit and cause corrosion or damage to the drive shaft.

- Wipe off the frost in the chamber with a soft cloth to prevent it from staining the sample or eroding the chamber. If the rotor chamber is dirty, clean it with cloth or sponge moistened with a neutral detergent solution.
- If dew drops are staying in the rotor chamber, dry the chamber with a soft cloth.

3) Drive shaft

- Wipe the drive shaft with soft cloth, and then coat some silicone grease on it.
- To prevent scuffing of the rotor, wipe a small amount of lubricant by a cloth on the drive shaft's screw once a month.

4) The door

- Clean and sterilize the door using the same method specified in the step 1).

5) Rotor

- To prevent corrosion, please remove the rotor from the rotor chamber after use. If a rotor is equipped with a cover, detach the cover and invert the rotor to dry the tube holes.
- If a sample is leaked in the rotor, first rinse the rotor with water, and then apply a small amount of silicon grease to it when it is completely dried. (Purchase the silicone grease separately.)

- For details please refer to rotor instruction manual.

10.2 Consumable Parts

The following table lists the consumable parts of this centrifuge. It is recommended to replace those parts within its lifespan. The timing of replacement varies depending on the operation environment and condition.

No.	Description	Replacement condition
1	Gas spring	The door falls naturally or lifting becomes heavy (around 10,000 times of opening and closing).
2	Chamber sealing rubber	A crack or deterioration is observed. (Rubber parts may deteriorate faster if chemicals are splashed on the surface.)
3	Door sealing rubber	
4	Rubber sleeve of temperature sensor	
5	Lock hole rubber	

11 Troubleshooting

11.1 Common malfunction list

This centrifuge is designed with self-diagnosing function. For example, an error code of the fault found will be displayed at the right bottom corner of the screen.



 **WARNING:** Do not open the door when the rotor is rotating.





Table 11-1 Error code

Symptom	Causes	Solution	
Nothing appears on the screen when the power is turned on.	<ul style="list-style-type: none"> Power socket blackout. The fuse is blown out. 	<ul style="list-style-type: none"> Remove the trouble and power again. Replace the fuse. 	
Error code E-xx appeared on the right corner of Screen.	E-02 Door Open	<ul style="list-style-type: none"> The door is open while the rotor is rotating. The  button is pressed while the door is open. 	<ul style="list-style-type: none"> Close the door immediately. Close the door, and then press the  button.
	E-03 Rotor ID	The centrifuge can not identify the rotor	Check the rotor Reconfirm the ID code of the rotor and make a correct selection.
	E-04 Temp Ctrl	<ul style="list-style-type: none"> Refrigeration ability is insufficient The air inlets on both sides of the centrifuge are blocked. Too much dust is deposited on the radiator. Something is wrong with the refrigeration parts 	<ul style="list-style-type: none"> If the room temperature is high, lower it. Dredge the air inlets on the centrifuge. Clean the dust. Replace the damage part.
	E-06 Over Set	The setting speed or g-value is over the allowable range.	Check the settings and let it within the allowable range.
	E-09 Imbalance	<ul style="list-style-type: none"> The imbalance is over the allowable range. The machine is shocked during operation. 	<ul style="list-style-type: none"> Balance the sample to ensure imbalance is within the allowable range. Don't push/move the instrument when it is running.
	E-10~86	Read Maintenance manual.	Contact our sales or service representative. Inform them the alarm code.

■ Error code E1 to E9 is mainly related to misoperation. User can continue using the centrifuge after the malfunction is removed.

11.2 Identify the malfunction

Users can identify the malfunction by following the instructions.

- In the preparation mode, press the  button for 5 seconds, then the malfunction list appears on the screen. User can find the causes accordingly to the error code.
- Press  or  button to turn page, user can find the causes accordingly to the error code.
- If no button is pressed for 5 seconds or the  button is pressed, the centrifuge will return to the preparation mode.

12 Frequent problems and solutions

WARNING:

- Never open the door while the instrument is running.
- If the door is opened while the rotor is still rotating, close it immediately.

12.1 How to open the door

1) The condition with the power on

User can open the door only when the instrument is powered and the rotor is not rotating.

(1) When the instrument turns on the power switch, press  button to open the door. But 6 seconds later, the door will be locked again.

(2) The door will be unlocked by pressing the  button. But 6 seconds later, the door will be locked again.

(3) When the rotor is stopped, press  button to open the door.

2) The condition with the power off

If the door cannot be opened due to the power outage, try to use the following steps:

(1) Make sure that the rotor is not rotating.

- Listen carefully to make sure that no sound can be heard.
- Confirm that the rotor is not rotating through observation window.
- Please allow of a sufficient time before taking any further actions.

(2) Insert a screwdriver into the small hole to open the door.

- The small hole is located on the left upper side of the centrifuge.
- Insert a screwdriver into this hole, and then push the lock to open the door.

(3) While the screwdriver pushing the lock, user can open the door with your hand.

12.2 How to remove the rotor stuck on the shaft

When the rotor is placed on the driving shaft for a long time, or because of extensive vibration, it may be firmly stuck on the driving shaft and will be difficult to be removed. Under this condition, the driving shaft may be bended if improper operation is used.

Correct Procedures is as followings:

1) Fix the screw (included in the attachment tools of the centrifuge) into the central thread hole of the rotor.

- 2) Insert the screwdriver into the thread hole of the screw. With one hand holding the rotor and the other hand turn the screw right so that the screw can go down and touch the top of the drive shaft.
- 3) Continue screwing the bolt down, the rotor will be lifted up from the driving shaft.
- 4) Remove the rotor with both hands and put it on a horizontal table.
- 5) Turn the screw left and remove it from the rotor.
- 6) Inspect the drive shaft and the rotor. If any scratches are observed on their inner surfaces, contact with the service representatives.

 **WARNING:** In case that the rotor is stuck to the driving shaft, it is not allowed to remove the rotor using force. Otherwise, the drive shaft may be bended or damaged. User should remove the rotor following the above procedure.

13 List of applicable rotors and tubes

CAUTION:

- To use the rotor properly please read the instruction manual carefully.
- Do not run the centrifuge exceeding the allowable maximum speeds of the rotor, buckets, and adapters. Some adapters, tubes and bottles have a lower speed than the rotor.

13.1 Table of applicable rotors

Rotor type	Maximum speed	Actual capacity (ml×No. of tubes)	Tube/bottle	
	Maximum RCF		Part name	Size(Φ×L)mm
FA18B	18,000rpm 24,990×g	1.5/2.0×18	1.5/2ml tube	Φ10.5×41
FA15A	15,000rpm 21,658×g	1.5/2.0×24	1.5/2ml tube	Φ10.5×41
FA15B	15,000rpm 21,835×g	50×4	50 ml PP tube	Φ29×106
FA15C	15,000rpm 23,294×g	50×6	50ml PP tube	Φ29×106
FA15D	15,000rpm 20,900×g	100×4	100ml PP tube	Φ38×106
FA12A	12,000rpm 14,100×g	0.2×48	0.2ml tube	Φ6×24
FA10B	10,000rpm 11,400×g	50×6	50ml TC tube	Φ29×115
SW5	4,800rpm 4,173×g	250×4	250ml bottle	Φ61.6×135
SW5L	4,200rpm 3,550×g	250×4	250ml bottle	Φ61.6×135

Rotor type	Maximum speed	Actual capacity (ml×No. of tubes)	Tube/bottle	
	Maximum RCF		Part name	Size(Φ×L)mm
SW5MP	4,800rpm	Platex2	96 well microplate	128×86×14
	3,125×g		96 Deep well plate	128×86×55
SW4A	4,000rpm 2,950×g	-	-	-
FA18C	18,000rpm 28,978×g	10×10	10ml tube	Φ16×82
FA15E	15,000rpm 22,600×g	5×12	5 ml tube with V bottom	Φ16.7×60
FA15F	15,000rpm 22,600×g	5×16	5ml tube with round bottom	Φ13.5×53.5
FA12B	12,000rpm 13,840×g	2×48	1.5ml tube	Φ10.8×40.5
FA14C	14,000rpm 20,926×g	50×4	50ml TC tube	Φ29×115
FA5A	5,600rpm 4,733×g	15×12	15ml TC tube	Φ17×119
FA15G	15,000rpm 25,004×g	50×6	50ml TC Tube	Φ30×116
FA15H	15,000rpm 24,950×g	50×6	50ml PP tube	Φ29×113
FA15K	15,000rpm 23,210×g	5×20	5ml PP tube	Φ13.5×53.5
FA15L	15,000rpm 25,516×g	2×30	2ml PP tube	Φ10.8×42
FA14D	14,000rpm 20,203×g	0.2×48	0.2ml tube	Φ6×21.5
FA14E	14,000rpm 21,132×g	2×48	2ml PP tube	Φ10.8×42

13.2 Cleaning and sterilizing tubes and bottles

1) To choose optional conditions for cleaning and sterilizing the tubes and bottles, please refer to the following table.

Cleaning and sterilizing conditions for tubes and bottles

O: Applicable X: Inapplicable

Condition		Material	PA	PC	PP
Cleaning	Running water cleaning	Acidic detergent(pH5 or lower)	X	X	X
		Acidic detergent (higher than pH5)	O	O	O
		Alkaline detergent(higher than pH9)	O	X	O
		Alkaline detergent(pH9 or lower)	O	O	O
		Neutral detergent(pH7)	O	O	O
		Warm water (up to 70°C)	O	O	O
	Ultrasonic cleaning	Neutral detergent (pH7)	O	O	O
Sterilization	Autoclaving	115°C (0.7kg/cm ²) 30minutes	O	O	O
		121°C (1.0kg/cm ²) 20 minutes	X	O	O
		126°C (1.4kg/cm ²) 15 minutes	X	X	X
	Boiling	15 to 30 minutes	O	O	O
	Ultraviolet sterilization	200-300nm	X	X	X
	Gas sterilization	Ethylene oxide	O	X	O
		Formaldehyde	O	O	O

PA: Polyallomer; PC: Polycarbonate; PP: Polypropylene

2) Cleaning PC tubes and bottles

PC materials have low chemical stability against alkaline solutions, so avoid using detergents with pH higher than 9. Note that some neutral detergents' pH is still higher than 9 even if diluted according to the instruction. Use detergent with its pH between 7.0 and 9.0.

3) Sterilize PA, PC and PP tubes and bottles by autoclave

PA begins softening at about 120°C, and PC and PP at about 130°C. So disinfect PA tubes/bottles at 115°C (0.7kg/cm²) for 30 minutes and PC and PP tubes/bottles at 121°C (0.1kg/cm²) for 20 minutes when using the autoclaving. If the temperature is exceeded, the tubes/bottles may deform.

Please take the following instructions when using a sterilizing vessel:

- (1) Place bottles in vertical position with mouths upward. If bottles are inclined, they may deform due to gravity action.
- (2) Remove caps and inner covers to avoid deformation or rupture.
- (3) Take the bottles out till the sterilizing chamber cools down to the room temperature.
- 4) The lifetime of tubes and bottles

The lifetime of plastic tubes and bottles depends on the characteristics of samples, speed of the rotor, temperature and so on.

When the plastic tubes/bottles are used for ordinary centrifugation (pH between 5.0 and 9.0), their life expectancies are defined as follows:

When operated at the maximum speed:

High quality tubes and bottles (PA, PC, PP): 30~50 times

Ordinary tubes and bottles (PA, PC, PP): about 10 times

The lifetime of the plastic tubes/bottles also depend on the treatment conditions such as cleaning and sterilization.

14 Rotating radius of applicable rotors

Table 14.1 List of the maximum radius of rotors

Name	Rotor ID	Maximum radius(cm)	Name	Rotor ID	Maximum radius(cm)	Name	Rotor ID	Maximum radius(cm)
SW5L	15	17.4	FA18B	36	6.90	FA15A	19	8.61
FA15B	16	8.68	FA15C	18	9.26	FA15D	17	8.30
SW5	50	16.2	FA12A	03	8.76	FA10B	20	10.2
FA18C	01	8.00	SW5MP	55	12.1	SW4A	60	16.5
FA15E	06	9.00	FA15F	04	9.00	FA12B	02	8.61
FA14C	13	9.55	FA5A	07	13.4	FA15G	09	9.94

15 Calculating (RCF)

An RCF can be determined by the following calculation formula:

$$RCF = 1.118 \times r \times n^2 \times 10^{-5}$$

r: rotating radius, unit: cm, n: rotating speed, unit: r / min

16 Fuses

The electric system consists of control board, drive board, display board, sensors, motor, refrigerator, and fans etc.

Normal fuses: F5,F6,F7,F8; 3,15A, $\Phi 5 \times 20$, used for low voltage DC power protection;

Delayed fuses: F1, F2, F3: 10A, $\Phi 6 \times 30$, delay type, used for the compressor, the fan and main circuit protection;

 Unauthorized repairs, disassembly, and other services to the centrifuge are strictly prohibited.

17 Guarantee

■ Guarantee of the centrifuge

This centrifuge is guaranteed for one year from the date of installation or one and half years from out-of-factory (date depending on the first come one) while it has been operated and maintained properly.

■ Guarantee of the rotor

The rotor is guaranteed for 7 years from the date of delivery. When the rotor has been damaged by corrosion or material fatigue, please pay special attention on it and do not use the rotor any more.

We do not guarantee the centrifuge and the rotor under the following conditions even before the guarantee period expires:

- (1) Failures caused by incorrect installation
- (2) Failures caused by rough and/or improper operation
- (3) Failures caused by transportation or displacement after installation
- (4) Failures caused by unauthorized disassembly or modification
- (5) Failures caused by the use of non-Dynamica components such as rotors, buckets and adapters
- (6) Failures caused by natural disasters including fire, earthquakes and so on
- (7) Consumable parts and parts with a limited guarantee period

After-sales Service

Periodic maintenance is recommended to assure safe and efficient operation. If the centrifuge has something wrong, do not attempt to repair it by yourself. Contact our sales or service representative.



The Velocity Range

Bench Top Centrifuges

Dynamica Scientific Limited

4 Bain Square, Kirkton Campus,
Livingston EH54 7DQ, United Kingdom

P: +44 1908 211 900

F: +44 1908 211 909

Email: info@dynamica-eu.com

Web: www.dynamica-eu.com

Asia

Dynamica (Asia) Limited

Unit 06, 26/F Tower 1, Ever Gain Plaza,
88 Container Port Road, Kwai Chung
N.T., Hong Kong

P: +852 2751 9488

F: +852 2751 9477

Email: info@dynamica-asia.com

Web: www.dynamica-asia.com